

TB 9-6695-293-50

CHANGE 1

DEPARTMENT OF THE ARMY TECHNICAL BULLETIN

CALIBRATION PROCEDURE FOR CALIBRATOR, JOHN FLUKE, MODEL 5700A/() (WITH WIDEBAND AC VOLTAGE, OPTION 03); AMPLIFIER, JOHN FLUKE, MODEL 5725A/(); POWER AMPLIFIER, JOHN FLUKE, MODEL 5215A/CT; AND TRANSCONDUCTANCE AMPLIFIER, JOHN FLUKE MODEL 5220A/CT

Headquarters, Department of the Army, Washington, DC

5 July 2001

Approved for public release; distribution is unlimited.

TB 9-6695-293-50, 9 November 1998, is changed as follows:

1. Remove old pages and insert new pages as indicated below. New or changed material is indicated by a vertical bar in the margin of the page.

Remove pages

1 and 2
5 through 8
21 and 22
25 and 26

Insert pages

1 and 2
5 through 8
21 and 22
25 and 26

2. File this change sheet in front of the publication for reference purposes.

By Order of the Secretary of the Army:

ERIC K. SHINSEKI
General, United States Army
Chief of Staff

OFFICIAL:

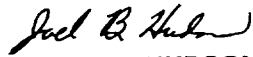

JOEL B. HUDSON
Administrative Assistant to the
Secretary of the Army

0120706

Distribution:

To be distributed in accordance with STD IDS No. RLC 1500, 6 March 1991, requirements for TB 9-6695-293-50.

PIN: 052435-001

***TB 9-6695-293-50**

SUPERSEDED COPY DATED 11 MAY 1992

DEPARTMENT OF THE ARMY TECHNICAL BULLETIN

CALIBRATION PROCEDURE FOR CALIBRATOR, JOHN FLUKE, MODEL 5700A/() (WITH WIDEBAND AC VOLTAGE, OPTION 03); AMPLIFIER, JOHN FLUKE, MODEL 5725A/(); POWER AMPLIFIER, JOHN FLUKE, MODEL 5215A/CT; AND TRANSCONDUCTANCE AMPLIFIER, JOHN FLUKE MODEL 5220A/CT

Headquarters, Department of the Army, Washington, DC
9 November 1998

Approved for public release; distribution is unlimited

REPORTING OF ERRORS

You can help improve this publication. If you find any mistakes or if you know of a way to improve the procedure, please let us know. Mail your letter or DA Form 2028 to: Commander, U. S. Army Aviation and Missile Command, ATTN: AMSAM-MMC-MA-NP, Redstone Arsenal, AL 35898-5230. A reply will be furnished to you. You may also send in your comments electronically to our e-mail address: 2028@redstone.army.mil or FAX 256-842-6546/DSN 788-6546.

		Paragraph	Page
SECTION	I.	IDENTIFICATION AND DESCRIPTION	
		Test Instrument identification.....	1 2
		Forms, records, and reports.....	2 3
		Calibration description.....	3 3
	II.	EQUIPMENT REQUIREMENTS	
		Equipment required.....	4 7
		Accessories required.....	5 7
	III.	CALIBRATION PROCESS FOR CALIBRATOR JOHN FLUKE, MODEL 5700A/()	
		Preliminary instructions.....	6 9
		Equipment setup.....	7 11
		Artifact calibration.....	8 12
		Dc voltage verification.....	9 14
		Resistance verification.....	10 15
		Dc current verification.....	11 17
		Ac current verification.....	12 19
		Ac voltage verification.....	13 22

*This bulletin supersedes TB 9-6695-293-50, dated 11 May 1992.

		Paragraph	Page
	Wideband ac voltage (option 03).....	14	25
	Final procedure.....	15	34
SECTION IV.	CALIBRATION PROCESS FOR AMPLIFIER JOHN FLUKE, MODEL 5725A/()		
	Preliminary instructions.....	16	35
	Equipment setup.....	17	35
	Artifact calibration 5725A/().....	18	35
	High ac voltage verification.....	19	36
	Dc current verification.....	20	37
	Ac current verification.....	21	38
	Final procedure.....	22	40
SECTION V.	CALIBRATION PROCESS FOR POWER AMPLIFIER JOHN FLUKE, MODEL 5215A/CT		
	Preliminary instructions.....	23	41
	Equipment setup.....	24	41
	High ac voltage.....	25	42
	Power supply.....	26	44
	Final procedure.....	27	44
SECTION VI.	CALIBRATION PROCESS FOR TRANSCONDUCTANCE AMPLIFIER, JOHN FLUKE, MODEL 5220A/CT		
	Preliminary instructions.....	28	45
	Equipment setup.....	29	45
	Dc accuracy and line regulation.....	30	47
	Frequency response.....	31	48
	Final procedure.....	32	50

**SECTION I
IDENTIFICATION AND DESCRIPTION**

1. Test Instrument Identification. This bulletin provides instructions for the calibration of Calibrator, John Fluke, Model 5700A/ () (with Wideband Ac Voltage, Option 03), Amplifier, John Fluke, Model 5725A/(); Power Amplifier, John Fluke, Model 5215A/CT; and Transconductance Amplifier, John Fluke, Model 5220A/CT. The manufacturer's manuals and MIS-35947 were used as the prime data sources in compiling these instructions. The equipment being calibrated will be referred to as the TI (test instrument) throughout this bulletin.

a. Model Variations. None.

b. Time and Technique. The time required for this calibration is approximately 8 hours, using the dc and low frequency technique.

2. Forms, Records, and Reports

a. Forms, records, and reports required for calibration personnel at all levels are prescribed by TB 750-25.

b. No physical adjustments will be performed on the calibrator, Model 5700A/() or amplifier, Model 5725A/(). Instead, an artifact calibration will be performed prior to performance verification tests. If an out-of-tolerance condition is detected, verify condition of standards, accessories, and equipment connections. If TI indications remain out of tolerance, repair action is required.

c. Adjustments to models 5215A/CT and 5220A/CT should be recorded and are designated (R) at the end of the sentence in which they appear. Report only those adjustments made and designated with (R).

3. Calibration Description. TI parameters and performance specifications which pertain to this calibration are listed in table 1.

Table 1. Calibration Description

Test instrument parameters	Performance specifications																																																																										
Calibrator, John Fluke, Model 5700A/()																																																																											
Dc voltage	Output: 0 to 1100 V Accuracy: ±(ppm reading + mV) Range : <table style="display: inline-table; vertical-align: middle;"> <tr> <td>220</td> <td>mV.....</td> <td>9 +</td> <td>0.8</td> </tr> <tr> <td>2.2</td> <td>V.....</td> <td>8 +</td> <td>1.2</td> </tr> <tr> <td>11</td> <td>V.....</td> <td>8 +</td> <td>4</td> </tr> <tr> <td>22</td> <td>V.....</td> <td>8 +</td> <td>8</td> </tr> <tr> <td>220</td> <td>V.....</td> <td>9 +</td> <td>100</td> </tr> <tr> <td>1100</td> <td>V.....</td> <td>11 +</td> <td>600</td> </tr> </table>			220	mV.....	9 +	0.8	2.2	V.....	8 +	1.2	11	V.....	8 +	4	22	V.....	8 +	8	220	V.....	9 +	100	1100	V.....	11 +	600																																																
220	mV.....	9 +	0.8																																																																								
2.2	V.....	8 +	1.2																																																																								
11	V.....	8 +	4																																																																								
22	V.....	8 +	8																																																																								
220	V.....	9 +	100																																																																								
1100	V.....	11 +	600																																																																								
Resistance	Output: 0 to 100 MW Accuracy: ±(ppm)¹ <table style="display: inline-table; vertical-align: middle;"> <tr> <td>Nominal output:</td> <td>0 W</td> <td></td> <td>50 mW</td> </tr> <tr> <td></td> <td>1.0 W</td> <td></td> <td>110</td> </tr> <tr> <td></td> <td>1.9 W</td> <td></td> <td>110</td> </tr> <tr> <td></td> <td>10 W</td> <td></td> <td>33</td> </tr> <tr> <td></td> <td>19 W</td> <td>.....</td> <td>31</td> </tr> <tr> <td></td> <td>100 W</td> <td></td> <td>20</td> </tr> <tr> <td></td> <td>190 W</td> <td></td> <td>20</td> </tr> <tr> <td></td> <td>1.0 kW</td> <td></td> <td>15</td> </tr> <tr> <td></td> <td>1.9 kW</td> <td></td> <td>15</td> </tr> <tr> <td></td> <td>10 kW</td> <td>.....</td> <td>14</td> </tr> <tr> <td></td> <td>19 kW</td> <td></td> <td>14</td> </tr> <tr> <td></td> <td>100 kW</td> <td></td> <td>16</td> </tr> <tr> <td></td> <td>190 kW</td> <td></td> <td>16</td> </tr> <tr> <td></td> <td>1.0 MW</td> <td></td> <td>23</td> </tr> <tr> <td></td> <td>1.9 MW</td> <td>.....</td> <td>24</td> </tr> <tr> <td></td> <td>10 MW</td> <td></td> <td>46</td> </tr> <tr> <td></td> <td>19 MW</td> <td></td> <td>55</td> </tr> <tr> <td></td> <td>100 MW</td> <td></td> <td>130</td> </tr> </table>			Nominal output:	0 W		50 mW		1.0 W		110		1.9 W		110		10 W		33		19 W	31		100 W		20		190 W		20		1.0 kW		15		1.9 kW		15		10 kW	14		19 kW		14		100 kW		16		190 kW		16		1.0 MW		23		1.9 MW	24		10 MW		46		19 MW		55		100 MW		130
Nominal output:	0 W		50 mW																																																																								
	1.0 W		110																																																																								
	1.9 W		110																																																																								
	10 W		33																																																																								
	19 W	31																																																																								
	100 W		20																																																																								
	190 W		20																																																																								
	1.0 kW		15																																																																								
	1.9 kW		15																																																																								
	10 kW	14																																																																								
	19 kW		14																																																																								
	100 kW		16																																																																								
	190 kW		16																																																																								
	1.0 MW		23																																																																								
	1.9 MW	24																																																																								
	10 MW		46																																																																								
	19 MW		55																																																																								
	100 MW		130																																																																								

See footnotes at end of table.

Table 1. Calibration Description – Continued

Test instrument parameters	Performance specifications																																																																																																																																																				
Calibrator, John Fluke, Model 5700A/()																																																																																																																																																					
Dc current	Output: 0 to 2.2 A Accuracy: ±(ppm reading + nA) Range: <table border="0" style="width: 100%; border-collapse: collapse;"> <tr> <td style="width: 10%;">220</td> <td style="width: 10%;">mA.....</td> <td style="width: 10%;">60</td> <td style="width: 10%;">+</td> <td style="width: 10%;">10</td> <td style="width: 10%;"></td> <td style="width: 10%;"></td> </tr> <tr> <td>2.2</td> <td>mA.....</td> <td>60</td> <td>+</td> <td>10</td> <td></td> <td></td> </tr> <tr> <td>22</td> <td>mA.....</td> <td>60</td> <td>+</td> <td>100</td> <td></td> <td></td> </tr> <tr> <td>220</td> <td>mA.....</td> <td>70</td> <td>+</td> <td>1.0</td> <td>mA</td> <td></td> </tr> <tr> <td>2.2</td> <td>A.....</td> <td>95</td> <td>+</td> <td>30</td> <td>mA</td> <td></td> </tr> </table>						220	mA.....	60	+	10			2.2	mA.....	60	+	10			22	mA.....	60	+	100			220	mA.....	70	+	1.0	mA		2.2	A.....	95	+	30	mA																																																																																																													
220	mA.....	60	+	10																																																																																																																																																	
2.2	mA.....	60	+	10																																																																																																																																																	
22	mA.....	60	+	100																																																																																																																																																	
220	mA.....	70	+	1.0	mA																																																																																																																																																
2.2	A.....	95	+	30	mA																																																																																																																																																
Ac current	Output: 9 mA to 2.2 A Accuracy: ±(ppm reading + nA) Range: <table border="0" style="width: 100%; border-collapse: collapse;"> <tr> <td colspan="2"></td> <td colspan="5" style="text-align: center;">Frequency:</td> </tr> <tr> <td rowspan="5" style="width: 10%;">220</td> <td rowspan="5" style="width: 10%;">mA</td> <td style="width: 10%;">10 – 20 Hz</td> <td style="width: 10%;">+</td> <td style="width: 10%;">800</td> <td style="width: 10%;"></td> <td style="width: 10%;">30</td> </tr> <tr> <td>20 – 40 Hz</td> <td>+</td> <td>420</td> <td></td> <td>25</td> </tr> <tr> <td>40 Hz – 1.0 kHz</td> <td>+</td> <td>160</td> <td></td> <td>20</td> </tr> <tr> <td>1.0 – 5.0 kHz</td> <td>+</td> <td>700</td> <td></td> <td>50</td> </tr> <tr> <td>5.0 – 10 kHz</td> <td>+</td> <td>.18 %</td> <td></td> <td>100</td> </tr> <tr> <td rowspan="5" style="width: 10%;">2.2</td> <td rowspan="5" style="width: 10%;">mA</td> <td style="width: 10%;">10 – 20 Hz</td> <td style="width: 10%;">+</td> <td style="width: 10%;">800</td> <td style="width: 10%;"></td> <td style="width: 10%;">50</td> </tr> <tr> <td>20 – 40 Hz</td> <td>+</td> <td>420</td> <td></td> <td>40</td> </tr> <tr> <td>40 Hz – 1.0 kHz</td> <td>+</td> <td>160</td> <td></td> <td>40</td> </tr> <tr> <td>1.0 – 5.0 kHz</td> <td>+</td> <td>700</td> <td></td> <td>500</td> </tr> <tr> <td>5.0 – 10 kHz</td> <td>+</td> <td>.18 %</td> <td></td> <td>1.0</td> <td>mA</td> </tr> <tr> <td rowspan="5" style="width: 10%;">22</td> <td rowspan="5" style="width: 10%;">mA</td> <td style="width: 10%;">10 – 20 Hz</td> <td style="width: 10%;">+</td> <td style="width: 10%;">800</td> <td style="width: 10%;"></td> <td style="width: 10%;">500</td> </tr> <tr> <td>20 – 40 Hz</td> <td>+</td> <td>420</td> <td></td> <td>400</td> </tr> <tr> <td>40 Hz – 1.0 kHz</td> <td>+</td> <td>160</td> <td></td> <td>400</td> </tr> <tr> <td>1.0 – 5.0 kHz</td> <td>+</td> <td>700</td> <td></td> <td>5.0</td> <td>mA</td> </tr> <tr> <td>5.0 – 10 kHz</td> <td>+</td> <td>.18 %</td> <td></td> <td>10</td> <td>mA</td> </tr> <tr> <td rowspan="5" style="width: 10%;">220</td> <td rowspan="5" style="width: 10%;">mA</td> <td style="width: 10%;">10 – 20 Hz</td> <td style="width: 10%;">+</td> <td style="width: 10%;">800</td> <td style="width: 10%;"></td> <td style="width: 10%;">5</td> <td>mA</td> </tr> <tr> <td>20 – 40 Hz</td> <td>+</td> <td>420</td> <td></td> <td>4</td> <td>mA</td> </tr> <tr> <td>40 Hz – 1.0 kHz</td> <td>+</td> <td>180</td> <td></td> <td>4</td> <td>mA</td> </tr> <tr> <td>1.0 – 5.0 kHz</td> <td>+</td> <td>700</td> <td></td> <td>50</td> <td>mA</td> </tr> <tr> <td>5.0 – 10 kHz</td> <td>+</td> <td>.18 %</td> <td></td> <td>100</td> <td>mA</td> </tr> <tr> <td rowspan="3" style="width: 10%;">2.2</td> <td rowspan="3" style="width: 10%;">A</td> <td style="width: 10%;">20 Hz – 1.0 kHz</td> <td style="width: 10%;">+</td> <td style="width: 10%;">750</td> <td style="width: 10%;"></td> <td style="width: 10%;">40</td> <td>mA</td> </tr> <tr> <td>1.0 – 5.0 kHz</td> <td>+</td> <td>850</td> <td></td> <td>100</td> <td>mA</td> </tr> <tr> <td>5.0 – 10 kHz</td> <td>+</td> <td>1.0 %</td> <td></td> <td>200</td> <td>mA</td> </tr> </table>								Frequency:					220	mA	10 – 20 Hz	+	800		30	20 – 40 Hz	+	420		25	40 Hz – 1.0 kHz	+	160		20	1.0 – 5.0 kHz	+	700		50	5.0 – 10 kHz	+	.18 %		100	2.2	mA	10 – 20 Hz	+	800		50	20 – 40 Hz	+	420		40	40 Hz – 1.0 kHz	+	160		40	1.0 – 5.0 kHz	+	700		500	5.0 – 10 kHz	+	.18 %		1.0	mA	22	mA	10 – 20 Hz	+	800		500	20 – 40 Hz	+	420		400	40 Hz – 1.0 kHz	+	160		400	1.0 – 5.0 kHz	+	700		5.0	mA	5.0 – 10 kHz	+	.18 %		10	mA	220	mA	10 – 20 Hz	+	800		5	mA	20 – 40 Hz	+	420		4	mA	40 Hz – 1.0 kHz	+	180		4	mA	1.0 – 5.0 kHz	+	700		50	mA	5.0 – 10 kHz	+	.18 %		100	mA	2.2	A	20 Hz – 1.0 kHz	+	750		40	mA	1.0 – 5.0 kHz	+	850		100	mA	5.0 – 10 kHz	+	1.0 %		200	mA
		Frequency:																																																																																																																																																			
220	mA	10 – 20 Hz	+	800		30																																																																																																																																															
		20 – 40 Hz	+	420		25																																																																																																																																															
		40 Hz – 1.0 kHz	+	160		20																																																																																																																																															
		1.0 – 5.0 kHz	+	700		50																																																																																																																																															
		5.0 – 10 kHz	+	.18 %		100																																																																																																																																															
2.2	mA	10 – 20 Hz	+	800		50																																																																																																																																															
		20 – 40 Hz	+	420		40																																																																																																																																															
		40 Hz – 1.0 kHz	+	160		40																																																																																																																																															
		1.0 – 5.0 kHz	+	700		500																																																																																																																																															
		5.0 – 10 kHz	+	.18 %		1.0	mA																																																																																																																																														
22	mA	10 – 20 Hz	+	800		500																																																																																																																																															
		20 – 40 Hz	+	420		400																																																																																																																																															
		40 Hz – 1.0 kHz	+	160		400																																																																																																																																															
		1.0 – 5.0 kHz	+	700		5.0	mA																																																																																																																																														
		5.0 – 10 kHz	+	.18 %		10	mA																																																																																																																																														
220	mA	10 – 20 Hz	+	800		5	mA																																																																																																																																														
		20 – 40 Hz	+	420		4	mA																																																																																																																																														
		40 Hz – 1.0 kHz	+	180		4	mA																																																																																																																																														
		1.0 – 5.0 kHz	+	700		50	mA																																																																																																																																														
		5.0 – 10 kHz	+	.18 %		100	mA																																																																																																																																														
2.2	A	20 Hz – 1.0 kHz	+	750		40	mA																																																																																																																																														
		1.0 – 5.0 kHz	+	850		100	mA																																																																																																																																														
		5.0 – 10 kHz	+	1.0 %		200	mA																																																																																																																																														
Ac voltage	Output: 220 mV – 1100 V Accuracy: ±(ppm reading + mV)² Range: <table border="0" style="width: 100%; border-collapse: collapse;"> <tr> <td colspan="2"></td> <td colspan="5" style="text-align: center;">Frequency:</td> </tr> <tr> <td rowspan="7" style="width: 10%;">2.2</td> <td rowspan="7" style="width: 10%;">mV</td> <td style="width: 10%;">10 – 20 Hz</td> <td style="width: 10%;">+</td> <td style="width: 10%;">600</td> <td style="width: 10%;"></td> <td style="width: 10%;">5</td> </tr> <tr> <td>20 – 40 Hz</td> <td>+</td> <td>240</td> <td></td> <td>5</td> </tr> <tr> <td>40 Hz – 20 kHz</td> <td>+</td> <td>120</td> <td></td> <td>5</td> </tr> <tr> <td>20 – 50 kHz</td> <td>+</td> <td>410</td> <td></td> <td>5</td> </tr> <tr> <td>50 – 100 kHz</td> <td>+</td> <td>950</td> <td></td> <td>8</td> </tr> <tr> <td>100 – 300 kHz</td> <td>+</td> <td>.13 %</td> <td></td> <td>15</td> </tr> <tr> <td>300 – 500 kHz</td> <td>+</td> <td>.18 %</td> <td></td> <td>30</td> </tr> <tr> <td rowspan="5" style="width: 10%;">22</td> <td rowspan="5" style="width: 10%;">mV</td> <td style="width: 10%;">10 – 20 Hz</td> <td style="width: 10%;">+</td> <td style="width: 10%;">600</td> <td style="width: 10%;"></td> <td style="width: 10%;">6</td> </tr> <tr> <td>20 – 40 Hz</td> <td>+</td> <td>240</td> <td></td> <td>6</td> </tr> <tr> <td>40 Hz – 20 kHz</td> <td>+</td> <td>120</td> <td></td> <td>6</td> </tr> <tr> <td>20 – 50 kHz</td> <td>+</td> <td>410</td> <td></td> <td>6</td> </tr> <tr> <td>50 – 100 kHz</td> <td>+</td> <td>950</td> <td></td> <td>8</td> </tr> </table>								Frequency:					2.2	mV	10 – 20 Hz	+	600		5	20 – 40 Hz	+	240		5	40 Hz – 20 kHz	+	120		5	20 – 50 kHz	+	410		5	50 – 100 kHz	+	950		8	100 – 300 kHz	+	.13 %		15	300 – 500 kHz	+	.18 %		30	22	mV	10 – 20 Hz	+	600		6	20 – 40 Hz	+	240		6	40 Hz – 20 kHz	+	120		6	20 – 50 kHz	+	410		6	50 – 100 kHz	+	950		8																																																																								
		Frequency:																																																																																																																																																			
2.2	mV	10 – 20 Hz	+	600		5																																																																																																																																															
		20 – 40 Hz	+	240		5																																																																																																																																															
		40 Hz – 20 kHz	+	120		5																																																																																																																																															
		20 – 50 kHz	+	410		5																																																																																																																																															
		50 – 100 kHz	+	950		8																																																																																																																																															
		100 – 300 kHz	+	.13 %		15																																																																																																																																															
		300 – 500 kHz	+	.18 %		30																																																																																																																																															
22	mV	10 – 20 Hz	+	600		6																																																																																																																																															
		20 – 40 Hz	+	240		6																																																																																																																																															
		40 Hz – 20 kHz	+	120		6																																																																																																																																															
		20 – 50 kHz	+	410		6																																																																																																																																															
		50 – 100 kHz	+	950		8																																																																																																																																															

See footnotes at end of table.

Table 1. Calibration Description – Continued

Test instrument parameters	Performance specifications			
Calibrator, John Fluke, Model 5700A/()				
Ac voltage (cont.)	22 mV	100 - 300 kHz	.13 % + 15	
		300 - 500 kHz	.18 % + 30	
		500 kHz - 1.0 MHz	.48 % + 40	
	220 mV	10 - 20 Hz	600 + 16	
		20 - 40 Hz	240 + 10	
		40 Hz - 20 kHz	110 + 10	
20 - 50 kHz		360 + 10		
50 - 100 kHz		900 + 30		
100 - 300 kHz		.11 % + 30		
300 - 500 kHz 500 kHz - 1.0 MHz		.18 % + 40 .36 % + 100		
2.2 V	10 - 20 Hz	600 + 100		
	20 - 40 Hz	180 + 30		
	40 Hz - 20 kHz	85 + 7		
	20 - 50 kHz	140 + 20		
	50 - 100 kHz	280 + 80		
	100 - 300 kHz	480 + 150		
	300 - 500 kHz 500 kHz - 1.0 MHz	.12 % + 400 .24 % + 1.0 mV		
22 V	10 - 20 Hz	600 + 1.0 mV		
	20 - 40 Hz	180 + 300		
	40 Hz - 20 kHz	85 + 70		
	20 - 50 kHz	140 + 200		
	50 - 100 kHz	280 + 400		
	100 - 300 kHz	600 + 1.7 mV		
	300 - 500 kHz 500 kHz - 1.0 MHz	.14 % + 5.0 mV .30 % + 9.0 mV		
220 V	10 - 20 Hz	600 + 10 mV		
	20 - 40 Hz	180 + 3.0 mV		
	40 Hz - 20 kHz	90 + 1.0 mV		
	20 - 50 kHz	250 + 4.0 mV		
	50 - 100 kHz	600 + 10 mV		
	100 - 220 kHz	.16 % + 110 mV		
	DELETE LINE DELETE LINE			
1100 V	50 Hz - 1.0 kHz	90 + 4.0 mV		
	Frequency accuracy: Range: 10 Hz to 1 MHz Accuracy: ±0.01%			
Wideband ac voltage (Option 03)	Amplitude flatness, 1 kHz reference: ±(% of output + mV) Frequency: 10 Hz to 30 MHz			
	Frequency	Voltage range		
		1.1 mV	3 mV	>3 mV
	10 Hz to 30 Hz	.3 + 0	.3 + 0	.3 + 0
	30 Hz to 120 kHz	.1 + 0	.1 + 0	.1 + 0
	120 kHz to 2.0 MHz	.2 + 3	.1 + 3	.1 + 3
	2.0 MHz to 10 MHz	.4 + 3	.3 + 3	.2 + 3
	10 MHz to 20 MHz	.6 + 3	.5 + 3	.4 + 3
20 MHz to 30 MHz	1.5 + 15	1.5 + 3	1.0 + 3	

TB 9-6695-293-50

See footnotes at end of table.

Table 1. Calibration Description - Continued

Test instrument parameters	Performance specifications ¹
Power Amplifier, John Fluke, Model 5215A/CT	
Ac voltage	Output: 100 to 1100 V ac Accuracy: ±(% of setting + mV) Frequency: 20 to 30 Hz .12 + 50 30 to 50 Hz .05 + 0 50 Hz to 20 kHz .04 + 20 20 to 50 kHz .08 + 50 50 to 100 kHz .2 + 0
Transconductance Amplifier, John Fluke, Model 5220A/CT	
Dc current	Output: 1.0 to 20 A dc Accuracy: ±(% of reading + mA) Output: 1 to 10 A .03 + 1.0 10 to 20 A .06 + 1.0
Ac current	Output: 1.0 to 10 A ac Accuracy: ±(% of reading +mA) <u>Frequency</u> 20 Hz to 3 kHz .16 + 0 3 to 5 kHz .16 + 1.0

¹Listed accuracies are for 4-wire connections; add .025W for 2-wire accuracies.

²Maximum V-Hz product is (2.2 x 10⁷) to 220 V and from 220 to 1100 V frequency limits are 50 Hz to 1 kHz.

³Range boundaries are at voltage points: dBm reference = 50W; dBm levels are approximate.

SECTION II EQUIPMENT REQUIREMENTS

4. Equipment Required. Table 2 identifies the specific equipment to be used in this calibration procedure. This equipment is issued with Secondary Reference Standards Set, NSN 4931-00-621-7878. Alternate items may be used by the calibrating activity. The items selected must be verified to perform satisfactorily prior to use and must bear evidence of current calibration. The equipment must meet or exceed the minimum use specifications listed in table 2.

5. Accessories Required. The accessories required for this calibration are common usage accessories, issued as indicated in paragraph 4 above, and are not listed in calibration procedure.

TB 9-6695-293-50

Table 2. Minimum Specifications of Equipment Required

Common name	Minimum use specifications	Manufacturer and model (part number)
AC MEASUREMENT STANDARD	Range: 2.0 mV to 1000 V ac Accuracy: Test report¹	John Fluke, Model 5790A (5790A)
AC SHUNT SET	Range: 10 mA to 10 A Accuracy: Test report¹	Holt Instrument Laboratories, Model HCS1 (MIS-10235)
DC REFERENCE STANDARD	Range: 10 V dc Accuracy: Test report	John Fluke, Model 732A (732A)/(732B)
FREQUENCY COUNTER	Range: 10 Hz to 30 MHz Accuracy: ±0.0025%	Hewlett-Packard, Model 5345A (MIS-28754/1 Type 1) w/5355A (5355A)
MULTIMETER	Dc volts: Range: 100 mV through 1000 V Accuracy: From ±2.1 ppm @ 10 V to 5.2 ppm at 500 V ² Dc current: Range: 100 mA through 100 mA Accuracy: From ±13 ppm @ 10 mA to 28 ppm at 100 mA ³ Resistance: Range: 0 through 1 MW Accuracy: From ±2.2 ppm @ 10 kW to 11 ppm at 1 MW ²	Hewlett-Packard, Model 3458A/E02 (MIS-35947/1 Type 2)
RESISTANCE STANDARD	Range: 100W to 1000W Accuracy: ±1.0%	Biddle Instruments, Model 71-631 (7910328)
RESISTANCE MEASURING SYSTEM	Range: 1.9 to 100 MW Accuracy: From ±10 ppm @ 190 MW to 32.5 ppm at 100 MW	ESI, Model SP2980 (MIS-10281)
STANDARD RESISTOR NO. 1	Value: 10 kW Accuracy: Test report	General Radio, Type 1444A (MIS-10400)
STANDARD RESISTOR NO. 2	Value: 1.0W Accuracy: Test report	L&N, Model 4020B (8616289)
STANDARD RESISTOR NO. 3	Value: .10W Accuracy: Test report²	L&N, Model 4221B (8616294)
STANDARD RESISTOR NO. 4	Value: .010W Accuracy: Test report²	Biddle Gray, Model 601235 (7902994)
STANDARD RESISTOR NO. 5	Value: .001W Accuracy: Test report²	Biddle Gray, Model 601240 (7902993)

¹Combined accuracy of ac shunt set and ac measurement standard is : From ±50 ppm @ 10 mA, 1 kHz to ±.255% @2.0 A, 10 kHz.

²Utilizes manufacturer's 24-hour specification for dc voltage, resistance (0 through 1 MW), and dc current (100 mA) to 100 mA).

³Combined accuracy of multimeter and standard resistor No. 3 is ±0.002%, No. 4 is ±0.01%, and No. 5 is +0.016%.

**SECTION III
CALIBRATION PROCESS FOR
CALIBRATOR, JOHN FLUKE, MODEL 5700A/()**

6. Preliminary Instructions

a. The instructions outlined in paragraphs **6** and **7** are preparatory to the calibration process. Personnel should become familiar with the entire bulletin before beginning the calibration.

b. Items of equipment used in this procedure are referenced within the text by common name as listed in table 2.

c. Unless otherwise specified, verify the results of each test and, whenever the test requirement is not met, take corrective action before continuing with the calibration. Additional maintenance information is contained in the manufacturer's manual for this TI.

d. Unless otherwise specified, all controls and control settings refer to the TI.

e. Multimeter, Hewlett-Packard, Model 3458A, Characterization

NOTE

The characterization is required to establish the manufacturer's 24-hour specifications. If ambient temperature drifts more than 1 degree Celsius prior to completing paragraphs **9** through **11** below, the characterization (and paragraph(s) must be repeated.

NOTE

Control and control settings in this paragraph refer to the multimeter, unless otherwise specified.

- (1) Remove all external input signals from the front and rear terminals.
- (2) Select the **DCV FUNCTION** and the **100 mV RANGE**.
- (3) Set front panel **TERMINALS** pushbutton to **FRONT** position.
- (4) Ensure that at least a 4-hour warmup has elapsed since power was applied.

TB 9-6695-293-50

(5) Front Terminal Offset:

(a) Connect a four-terminal short across the front panel terminals as shown in figure 1.

(b) After connecting the short, allow 5 minutes for thermal equilibrium.

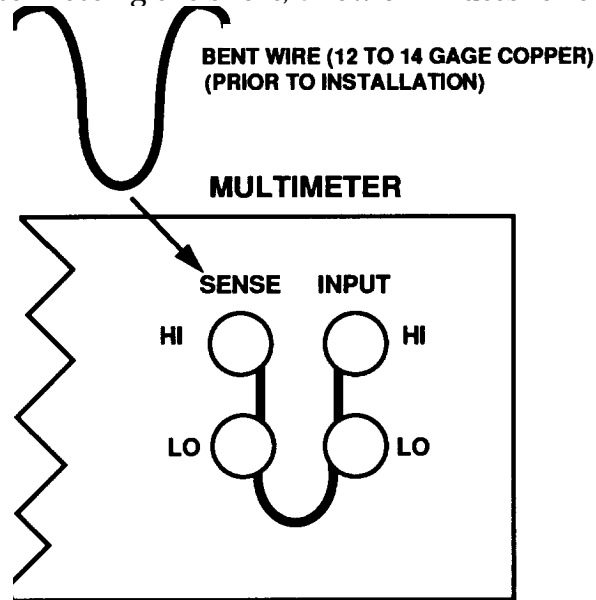

Figure 1. Four-terminal short.

NOTE

Take precautions to prevent thermal changes near four-wire short. Do not touch short after it is installed. If drafts exist, cover **INPUT** terminals/short to minimize thermal changes.

(c) Execute the **CAL 0** command by pressing: **Blue**, **AUTO CAL**, **0**, **,**, **,**, **3**, **4**, **5**, **8**, and **ENTER** keys. This adjustment takes about 5 minutes. When completed, the multimeter will return to displaying dc voltage measurements.

(d) Set to **10 V RANGE** and remove four-terminal short from front terminals.

(6) Dc Gain:

(a) Select **DCV FUNCTION** and set front panel **TERMINALS** pushbutton to **FRONT**.

(b) Connect dc reference standard 10 V output to **INPUT HI**, **LO**, and **GUARD** terminals.

(c) Execute the **CAL** command specifying the 10 V test report value of dc reference standard. For example, if the test report value is 10.000001 V press: **Blue, AUTO CAL, 1, 0, ., 0, 0, 0, 0, 0, 1, ., ., 3, 4, 5, 8** and **ENTER** keys. This adjustment takes about 2 minutes and, when completed, multimeter will display dc voltage measurements.

(d) Disconnect dc reference standard from multimeter.

(7) Resistance and Dc Current:

(a) Select the four-wire ohms measurement **FUNCTION** and enable the offset compensation by pressing: **Blue, OHMF/OHM, OFFSET COMPW, ↑** , and **ENTER** keys.

(b) Connect standard resistor No. 1 to multimeter using four-wire technique and set **GUARD** pushbutton to the **TO LO** position

(c) Execute the **CAL** command specifying the test report value of the standard resistor. For example, if the test report value is 10.00011 k Ω press: **Blue, AUTO CAL, 1, 0, ., 0, 0, 0, 1, 1, E, 3, ., ., 3, 4, 5, 8**, and **ENTER** keys. This adjustment takes about 12 minutes and, when completed, multimeter will return to displaying resistance readings.

(d) Disconnect standard resistor and execute **ACAL AC** by pressing: **AUTO CAL, ↓, ↓, 3, 4, 5, 8**, and **ENTER** keys.

7. Equipment Setup

WARNING

HIGH VOLTAGE is used or exposed during the performance of this calibration. DEATH ON CONTACT may result if personnel fail to observe safety precautions. REDUCE OUTPUT(S) to minimum after each step within the performance check where applicable.

- a.** Connect TI to a 115 V ac source.

NOTE

If TI is being calibrated in conjunction with a 5725A/() amplifier, the 5725A/() should be connected to TI at this time. The 5725A/() should be warmed up for 30 minutes and in the **ON** state during **b** below and during paragraph **8** below. Afterwards, the 5725A/() could be in the **OFF** state until performance of section IV below.

- b.** Set **POWER** switch to **ON** and allow at least 30 minutes to warm up.

NOTE

When turned on, the TI undergoes a self test. If self test fails, take corrective action before proceeding.

- c. Perform the **DC ZERO CALIBRATION** by pressing the following softkeys:
 - (1) **SETUP MENUS**
 - (2) **CAL**
 - (3) **ZERO**

8. Artifact Calibration

NOTE

Through the following calibration steps the TI display screen will provide some instructions. When the display reads "...Please Wait..." wait until display changes before continuing with next step.

- a. Press **SETUP MENUS** softkey.
- b. Press **CAL** softkey; then press **CAL** softkey again.
- c. Press one of the softkeys under the **CALIBRATION** display.
- d. Enter ambient temperature and press **ENTER**.
- e. Connect equipment as shown in figure 2.

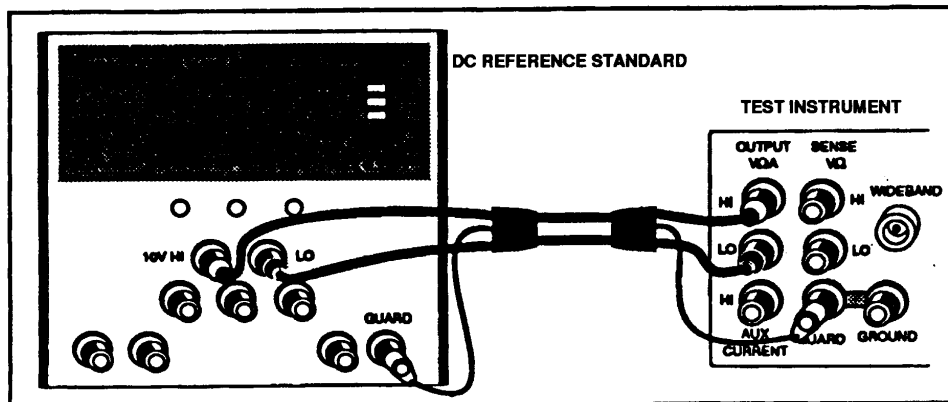

Figure 2. 10 V internal calibration.

- f. Enter the test report value of the dc reference standard 10 V output; then press **ENTER**.

- g.** Press **PROCEED** softkey.
- h.** Reverse the **HI** and **LO** connections at the dc reference standard; then press **ENTER**.
- i.** Connect equipment as shown in figure 3.

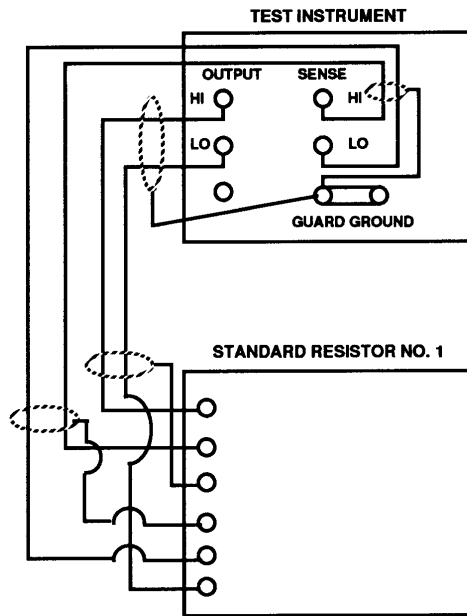

Figure 3. 10 kΩ internal calibration.

- j.** Enter the test report value of standard resistor No. 1, then press **ENTER**.
- k.** Press the **PROCEED** softkey.
- l.** Connect equipment as shown in figure 4.

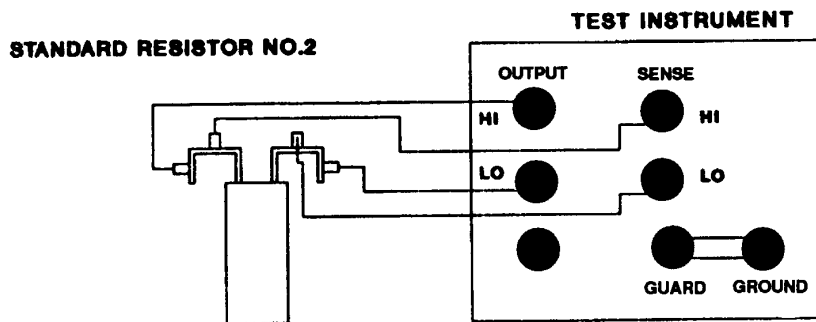

Figure 4. 1Ω internal calibration.

TB 9-6695-293-50

- m.** Enter the test report value of standard resistor No. 2; then press **ENTER**.
- n.** Press the **PROCEED** softkey; then remove standard resistor from equipment setup.
- o.** Set the rear panel **CALIBRATION** switch to **ENABLE**; then press **STORE VALUES** softkey.
- p.** Press the **DONE WITH CAL** softkey.
- q.** Set the rear panel **CALIBRATION** switch to **NORMAL**.
- r.** Press **RESET** pushbutton.

9. Dc Voltage Verification

NOTE

The characterization of the multimeter is required for this performance check. If ambient temperature drifts more than 1 degree Celsius (from time of characterization) prior to completing paragraph **9** below, the characterization (and paragraph **9**) must be repeated.

WARNING

The TI is capable of supplying lethal voltages. Do not make connections to the output terminals when any voltage is present. Placing the TI in **STANDBY** may not be enough to avoid shock hazard, since the **OPR/STBY** pushbutton could be pressed accidentally. Press the **RESET** pushbutton and verify that **STANDBY** is lit before making connections to the **OUTPUT** terminals.

- a.** Connect TI **OUTPUT HI, LO, and GUARD** terminals to multimeter **INPUT HI, LO, and GUARD** terminals. Ensure that TI **EX SENS** and **EX GRD** pushbuttons are in the off positions.
- b.** Set multimeter for most accurate dc voltage measurements and to the manual 100 mV range.
- c.** Set TI for a 100 mV dc output. Multimeter will indicate between 099.9983 and 100.0017 mV dc.
- d.** Set multimeter to 1 V range and set TI for a 1 V dc output. Multimeter will indicate between 0.9999908 and 1.0000092 V dc.

- e. Repeat **d** above for multimeter range settings and output voltages listed in table 3. Multimeter will indicate within the limits listed.

Table 3. Dc Voltage Linearity Test Multimeter Indications

Multimeter range setting (V dc)	Test instrument output (V dc)	Multimeter indications (V dc)	
		Min	Max
10	2	01.999980	02.000020
10	3	02.999972	03.000028
10	4	03.999964	04.000036
10	5	04.999956	05.000044
10	6	05.999948	06.000052
10	7	06.999940	07.000060
10	8	07.999932	08.000068
10	9	08.999924	09.000076
10	10	09.999916	10.000084
100	100	099.99900	100.00100
1000	500	0499.9939	0500.0061

- f. Set TI to the minimum output then press **RESET** pushbutton.

10. Resistance Verification

NOTE

The characterization of the multimeter is required for this performance check. If ambient temperature drifts more than 1 degree Celsius (from time of characterization) prior to completing paragraph **10** below, the characterization (and paragraph **10**) must be repeated.

- a. Connect equipment as shown in figure 5.

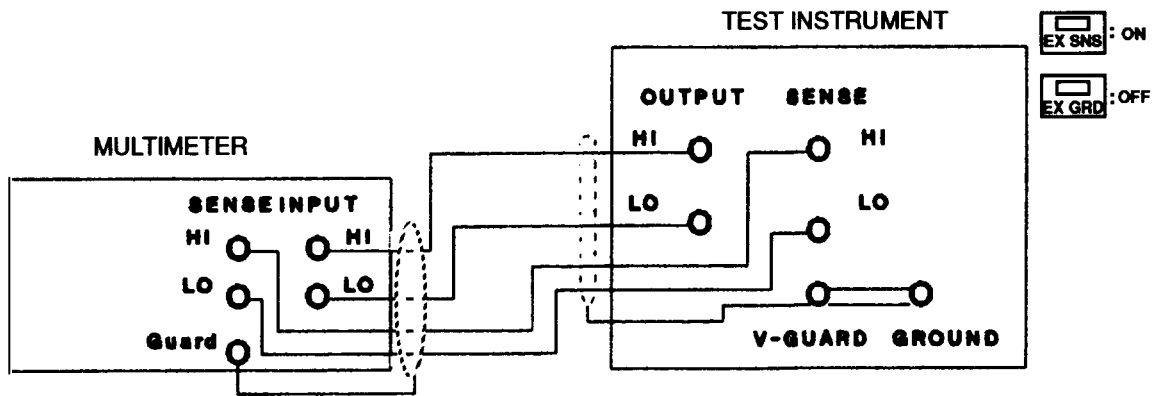

Figure 5. Resistance (0 through 1 MΩ).

TB 9-6695-293-50

b. Configure multimeter for most accurate four-wire resistance measurements. (Configuration modifications will be required depending on value of input resistance; e.g., set **0COMP** to **ON** until **100 kW**, then set **0COMP** to **OFF**.)

c. Set TI for a 1Ω output. Multimeter will indicate within ±110 ppm of displayed value on TI.

d. Repeat technique of **c** above for settings listed in table 4. Multimeter will indicate within the listed limits.

Table 4. Resistance

Test instrument output	Multimeter indication ±(ppm of test instrument displayed value)
1.9 W	110
10 W	33
19 W	31
100 W	20
190 W	20
1 kW	15
1.9 kW	15
10 kW	14
19 kW	14
100 kW	16
190 kW	16
1 MW	23
0 W	50 mW

e. Set TI to **STANDBY**.

f. Connect equipment as shown in figure 6.

g. Set TI for a 1.9 MΩ output. Measure resistance. Resistance measuring system will indicate within ±24 ppm of TI displayed value.

h. Set TI for a 10 MΩ output. Measure resistance. Resistance measuring system will indicate within ±46 ppm of TI displayed value.

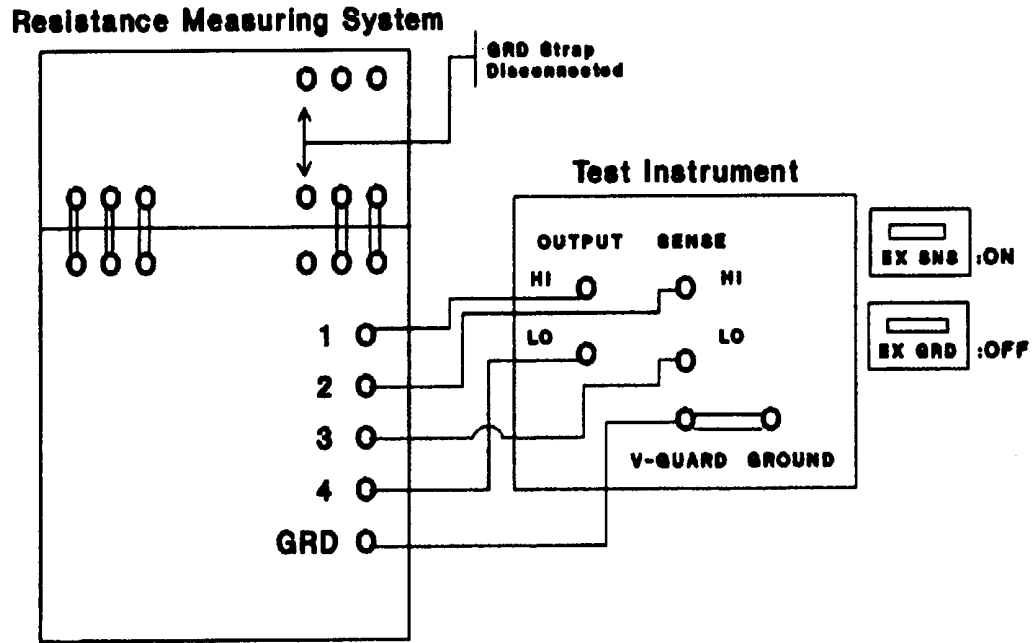

Figure 6. Resistance (1.9 through 19 MΩ).

- i. Set TI for a 19 MΩ output. Measure resistance. Resistance measuring system will indicate within ±55 ppm of TI displayed value.
- j. Set TI for a 100 MΩ output. Measure resistance. Resistance measuring system will indicate within ± 130 ppm of TI displayed value.
- k. Press **RESET**.

11. Dc Current Verification

NOTE

The characterization of the multimeter is required for this performance check. If ambient temperature drifts more than 1 degree Celsius (from time of characterization) prior to completing paragraph **11** below, the characterization (and paragraph **11**) must be repeated.

- a. Connect **OUTPUT HI, LO, and GUARD** terminals to multimeter **INPUT I, LO, and GUARD** terminals. Configure multimeter for most accurate dc current measurements.

TB 9-6695-293-50

b. Set TI for a 1 mA output.

c. Using output adjustment control, set TI for a 1.0000000 mA (± 10 digits) indication on multimeter. TI **Error** display will be within the limits listed in table 5.

Table 5. Dc Current

Test instrument		Error display Limits (\pm ppm)
Output		
1	mA	70
10	mA	70
100	mA	80
100	mA	160

d. Set TI for a -1 mA output.

e. Using output adjustment control, set TI for a -1.0000000 mA (± 10 digits) indication on multimeter. TI **Error** display will be within the limits listed in table 5.

f. Repeat technique of **b** through **e** above for values listed in table 5, section A. TI **Error** display will indicate within the listed limits.

g. Connect equipment as shown in figure 7.

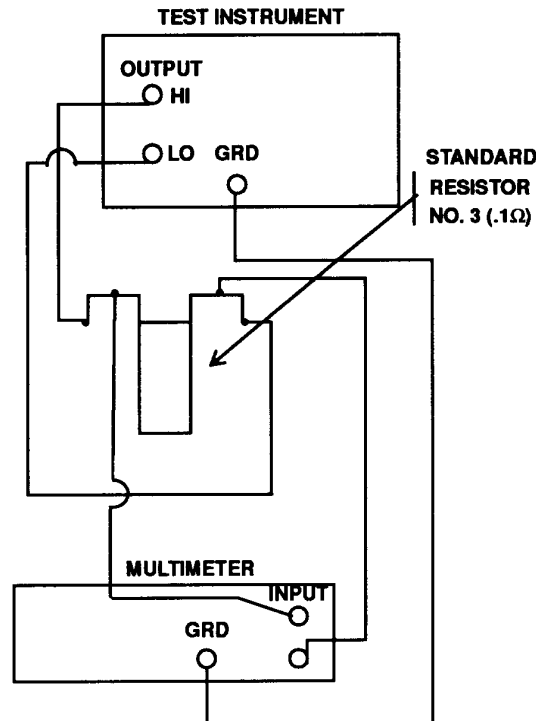

Figure 7. Dc current (1 and 2 A).

h. Configure multimeter for most accurate dc voltage measurements.

i. Set TI for a 1 A dc output and record multimeter indication.

j. Refer to test report for standard resistor No. 3 and divide test report value into multimeter indication recorded in **i** above. The calculated current will be between .999875 and 1.000125 A.

k. Repeat technique of **i** and **j** above for -1 A dc.

l. Repeat technique of **i** through **k** above for 2 A dc. The calculated current will be between (+ and -) 1.99978 and 2.00022 A.

12. Ac Current Verification

a. 10 mA to 2.0 A

(1) Connect equipment as shown in figure 8. Press **INPUT 1** pushbutton on ac measurement standard.

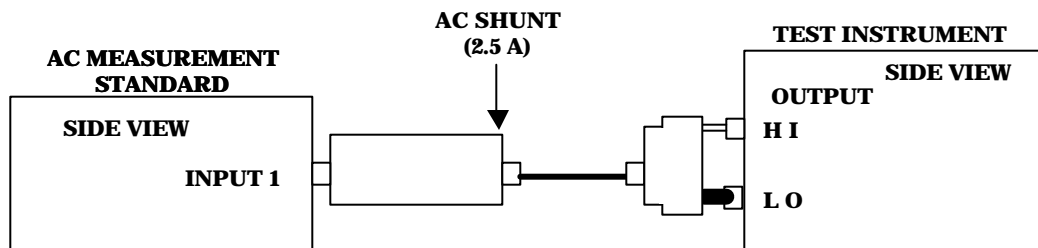

Figure 8. Ac current (10 mA to 2 A)

(2) Enter the ac-to-dc difference corrections for each shunt at each frequency in the appropriate column of table 6.

Table 6. Ac Current

Test instrument output		Ac measurement standard error display	Ac shunt ac-dc difference	Calculated error (± %)	Error limits (± %)
Current	Frequency				
2.0 A	3.0 kHz				0.090
	20 Hz				0.077
	10 kHz				1.010
1.0 A	1.0 kHz				0.079
	5.0 kHz				0.095
	10 kHz				1.020
100 mA	10 Hz				0.085
	20 Hz				0.046
	1.0 kHz				0.022
	5.0 kHz				0.120
	10 kHz				0.280
10 mA	10 Hz				0.085
	20 Hz				0.046
	1.0 kHz				0.020
	5.0 kHz				0.120
	10 kHz				0.280
1.0 mA	10 Hz		N/A	N/A	0.085
	20 Hz		N/A	N/A	0.046
	1.0 kHz		N/A	N/A	0.020
	5.0 kHz		N/A	N/A	0.120
	10 kHz		N/A	N/A	0.280
100 μA	10 Hz		N/A	N/A	0.110
	20 Hz		N/A	N/A	0.067
	1.0 kHz		N/A	N/A	0.036
	5.0 kHz		N/A	N/A	0.120
	10 kHz		N/A	N/A	0.280

(3) Set TI for a +2.0 A dc output. Allow at least 10 minutes for shunt stabilization.

NOTE

The 10 minute stabilization may only be required for the first measurement after ac shunt values are changed. Afterwards allow at least 1 minute after each TI output change before noting TI or multimeter indications.

(4) When the reading has settled, press **SET REF** soft key on ac measurement standard and set display to indicate **PCT** units.

NOTE

When **SET REF** is engaged the display shows the difference between an applied input and the stored reference, or average of references. The difference can be displayed in units of V (or mV), ppm, percent, or ratio. Once a reference has been established you can cycle through each choice by pressing any of the three softkeys below the display. The display will cycle through **PPM** (power on state), **PCT**, **VOLTS**, and **RATIO**, and displays the equation used in each case.

(5) Set TI for 2.0 A, 3.0 kHz ac output. Record ac measurement standard displayed error indication in appropriate column of table 6.

(6) Return to +2.0 A dc output that was set in (3) above and verify that the ac measurement standard error display returns to a zero reading ± 0.0010 PCT; if not, repeat technique of (3) through (5) above.

(7) Algebraically add the resulting error indication to the test reported ac-to-dc difference of the ac shunt. The result will be within the limits specified.

(8) Repeat technique of (5) through (7) above for 20 Hz and 10 kHz.

(9) Repeat technique of (2) through (8) above for 1.0 A, 100 mA and 10 mA using the appropriate ac shunts.

b. 1.0 mA and 100 mA

(1) Connect equipment as shown in figure 9. Set resistance standard dials to 000100.00. Press **INPUT 2** pushbutton on ac measurement standard.

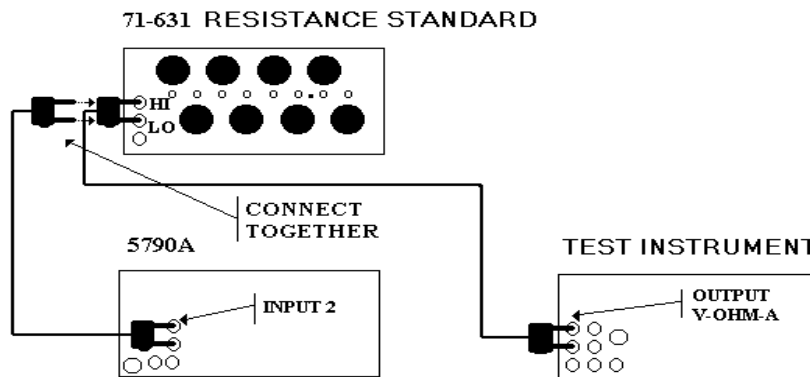

Figure 9. Ac current (1.0 mA and 100 μ A).

(2) Set TI for a +1.0 mA dc output.

TB 9-6695-293-50

(3) When the reading has settled, press **SET REF** soft key on ac measurement standard.

(4) Set TI for 1.0 mA, 1.0 kHz ac output. Record ac measurement standard displayed error indication in appropriate column of table 6. The result will be within the limits specified.

(5) Return to +1.0 mA dc output that was set in (2) above and verify that the ac measurement standard error display returns to a zero reading ± 0.010 PCT; if not, repeat technique of (2) through (4) above.

(6) Repeat technique of (4) and (5) above for 10 Hz, 20 Hz and 5 kHz and 10 kHz.

(7) Repeat technique of (2) through (6) above for 100 μ A but set the resistance standard dials to 001000.00.

13. Ac Voltage Verification

a. Frequency Accuracy

(1) Connect **OUTPUT HI** and **LO** terminals to frequency counter.

(2) Set TI for a 1 V, 10 Hz output. Frequency counter will indicate between 99.99 and 100.01 ms.

(3) Repeat technique of (2) above for the frequencies listed in table 7. Frequency counter will indicate within the listed limits.

Table 7. Ac Voltage, Frequency Accuracy

Test instrument frequency	Frequency counter indications			
	Min		Max	
15 Hz	66.66	ms	66.6733	ms
100 Hz	9.999	ms	10.001	ms
200 Hz	199.98	Hz	200.02	Hz
500 Hz	499.95	Hz	500.05	Hz
1 kHz	999.9	Hz	1000.1	kHz
5 kHz	4999.5	Hz	5000.1	Hz
10 kHz	9.999	kHz	10.001	kHz
50 kHz	49.995	kHz	50.005	kHz
100 kHz	99.99	kHz	100.01	kHz
140 kHz	139.986	kHz	140.014	kHz
200 kHz	199.98	kHz	200.02	kHz
500 kHz	499.95	kHz	500.05	kHz
1 MHz	999.9	kHz	1.0001	MHz

b. Ac Voltage (2 mV through 1000 V)

(1) Place ac measurement standard on top of TI and connect equipment as shown in figure 10. Press **INPUT 2** pushbutton on ac measurement standard.

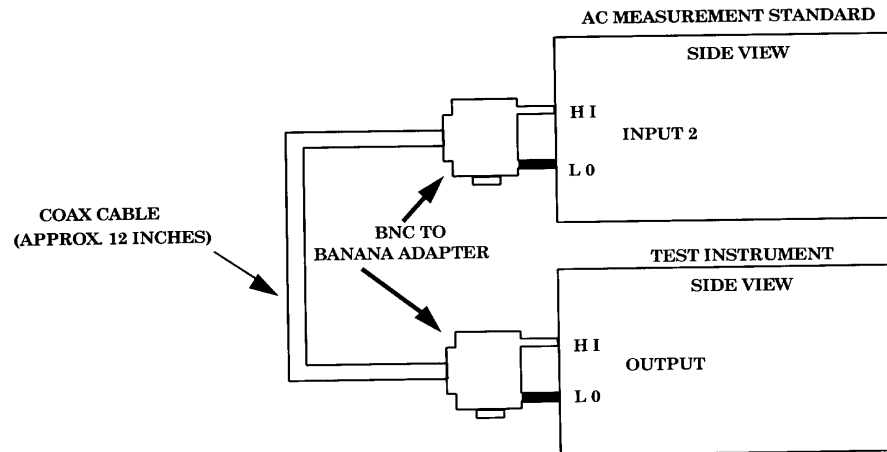

Figure 10. Ac voltage (2 mV through 1000 V)

(2) On the ac measurement standard, press the **UTIL MENU** pushbutton then the **MEAS CONTROL** soft key. Set **DIGITAL FILTER MODE** to **FAST** and **RESTART** to **MEDIUM**. Push the **DONE** soft key twice to return to the measurement display and set to **AUTO** range.

(3) Set TI for a 1 mV, 1 kHz output. Adjust TI output adjustment knob for an indication of 2.0000 mV (± 2 digits) on the ac measurement standard. Record the TI error display indication in table 8.

(4) Verify that the result is within the limits listed in table 8.

(5) Repeat technique of (3) and (4) above for remaining frequencies for 1 mV output level.

(6) Repeat technique of (3) through (5) above for the remaining output levels and frequencies listed in table 8. In (3) above, ± 5 digits can be used for output levels ≥ 100 mV.

Table 8. Ac Voltage, 2 mV through 1000 V

Test instrument		Measured Error (%)	Limits (0 ±%)
Output level	Frequency		
1 mV	10 Hz		0.560
1 mV	30 Hz		0.524
1 mV	1 kHz		0.512
1 mV	30 kHz		0.541
1 mV	90 kHz		0.895
1 mV	200 kHz		1.630
1 mV	400 kHz		3.180
1 mV	1 MHz		4.480
10 mV	10 Hz		0.120
10 mV	30 Hz		0.084
10 mV	1 kHz		0.072
10 mV	30 kHz		0.101
10 mV	90 kHz		0.175
10 mV	200 kHz		0.280
10 mV	400 kHz		0.480
10 mV	1 MHz		0.880
100 mV	10 Hz		0.076
100 mV	30 Hz		0.034
100 mV	1 kHz		0.021
100 mV	30 kHz		0.046
100 mV	90 kHz		0.120
100 mV	200 kHz		0.140
100 mV	400 kHz		0.220
100 mV	1 MHz		0.460
1.0 V	10 Hz		0.070
1.0 V	30 Hz		0.021
1.0 V	1 kHz		0.0092
1.0 V	30 kHz		0.016
1.0 V	90 kHz		0.036
1.0 V	200 kHz		0.063
1.0 V	400 kHz		0.160
1.0 V	1 MHz		0.340

Table 8. Ac Voltage, 2 mV through 1000 V - Continued

Test instrument		Measured error (%)	Limits (0 ±%)
Output level (V)	Frequency		
10 V	10 Hz		0.070
10 V	30 Hz		0.021
10 V	1 kHz		0.0092
10 V	30 kHz		0.016
10 V	90 kHz		0.032
10 V	200 kHz		0.077
10 V	400 kHz		0.190
10 V	1 MHz		0.390
100 V	10 Hz		0.070
100 V	30 Hz		0.021
100 V	1 kHz		0.010
100 V	30 kHz		0.029
100 V	90 kHz		0.070
100 V	200 kHz		0.270
DELETE LINE			
DELETE LINE			
1000 V	1 kHz		0.0094

14. Wideband Ac Voltage (Option 03)

a. Gain (Cable and 50W Termination) Calibration

- (1) Verify that TI has warmed up for at least 30 minutes.
- (2) Press **SETUP MENUS** soft key.
- (3) Press **CAL** soft key; then press **CAL** again.
- (4) Press **WIDEBAND GAIN** soft key.
- (5) Enter the ambient temperature and press **ENTER** pushbutton.
- (6) Connect TI as shown in figure 11 for positive gain calibration.
- (7) Press **ENTER** pushbutton.

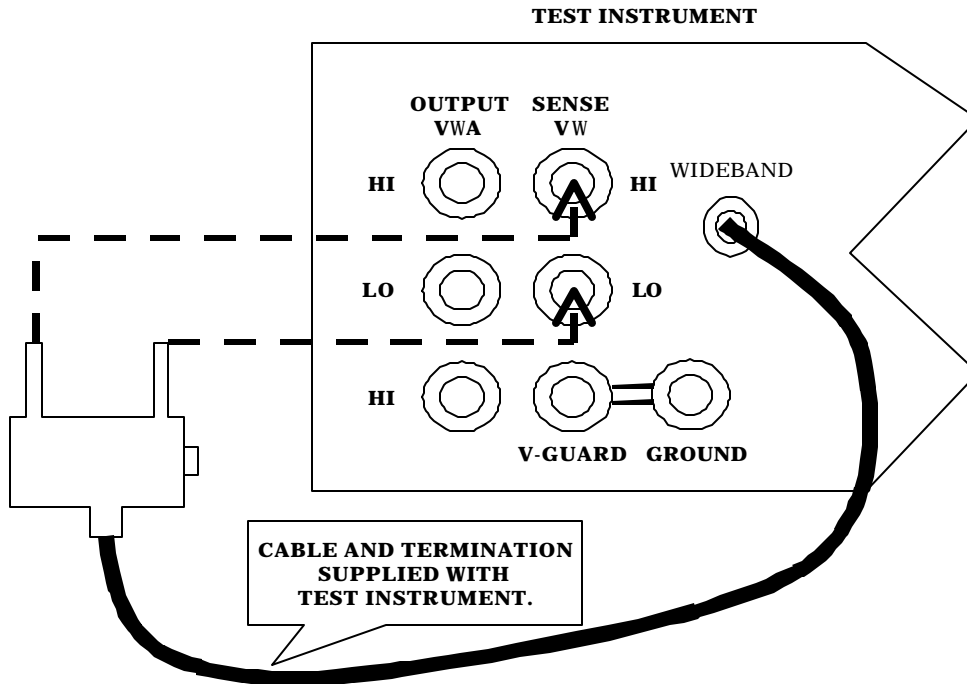

Figure 11. Gain calibration.

NOTE

As wideband gain calibration proceeds, messages appear on the display identifying all processes as they are encountered. Proceed to (8) below when positive gains calibration is complete.

(8) For negative gain calibration, reverse connection at the **SENSE** input so that center conductor is connected to **LO** and then press **ENTER** pushbutton.

(9) At completion of (8) above, set rear panel **CALIBRATION NORMAL/ENABLE** switch to **ENABLE** and press **STORE VALUES** soft key.

(10) Press **DONE WITH CAL** soft key until TI display returns to normal. Then set rear panel **CALIBRATION NORMAL/ENABLE** switch to **NORMAL**.

(11) Press **RESET** pushbutton.

NOTE

Paragraphs **b** through **d** below comprise the verification test for the wideband option. Paragraph **e** below is the flatness calibration procedure. Performance of **e** below is only required if an out-of-tolerance condition exists in **b** and **d** below or upon initial calibration of wideband option. In both cases paragraphs **a** above and **c** below must be completed prior to **d** and **e** below in order to establish, or characterize, voltage accuracies at 1 kHz. If an out-of-tolerance condition exists in **c** below, repeat **a** above and **c** below. If an out-of-tolerance condition still exists, a repair action is required.

b. Frequency Accuracy

- (1) Connect wideband output to frequency counter **CHANNEL A** input, using termination and cable supplied with TI. Set TI for a 0 dBm, 10 Hz wideband output.
- (2) Measure output frequency; frequency counter will indicate between 99.99 and 100.01 ms.
- (3) Adjust TI frequency to those listed in table 9. At each frequency setting repeat (2) above. Frequency counter will indicate within the listed limits.
- (4) Press **RESET** pushbutton.

Table 9. Wideband Frequency Accuracy

Test instrument frequency	Frequency counter indication	
	Min	Max
100 Hz	9.999 ms	10.001 ms
300 Hz	299.97 Hz	300.03 Hz
500 Hz	499.95 Hz	500.05 Hz
800 Hz	799.92 Hz	800.08 Hz
900 Hz	899.91 Hz	900.09 Hz
1 kHz	999.9 Hz	1.0001 kHz
1.19 kHz	1.189881 kHz	1.190119 kHz
2.2 MHz	2.19978 MHz	2.20022 MHz
3.5 MHz	3.49965 MHz	3.50035 MHz
3.8 MHz	3.79962 MHz	3.80038 MHz
10 MHz	9.999 MHz	10.001 MHz
20 MHz	19.998 MHz	20.002 MHz
30 MHz	29.997 MHz	30.003 MHz

TB 9-6695-293-50

c. 1 kHz Wideband Accuracy

(1) Connect equipment as shown in figure 12.

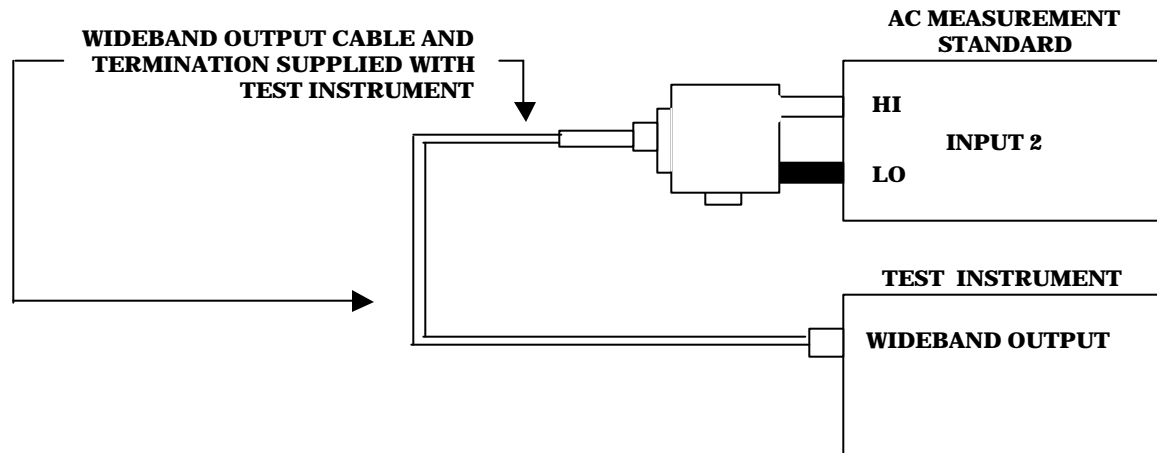

Figure 12. 1 kHz output level.

(2) Set ac measurement standard as specified in (a) through (g) below:

- (a) Press **INPUT 2** pushbutton.
- (b) Press **2.2 V RANGE** pushbutton.
- (c) Press **UTIL MENUS** pushbutton.
- (d) Select **MEAS CONTROL** soft key.
- (e) Select **FAST DIGITAL FILTER** mode.
- (f) Select **MEDIUM RESTART**.

- (g) Press the **DONE** soft key twice to return to measurement mode.
- (3) Set TI for a 2.1 V, 1 kHz wideband output.
- (4) Using output adjustment knob, adjust TI for an ac measurement standard indication of 2.100000 V (± 20 digits).
- (5) Record TI **Error** display indication (in %, including polarity) in table 10. Error will be within the limits specified.
- (6) Set ac measurement standard range display to auto and repeat technique of (3) through (5) above for remaining output levels listed in table 10.

Table 10. Wideband 1 kHz Accuracy

Wideband output level	Error display indication $\pm(\%)$	Limits %
2.1 V (± 20 digits)		.4238
1.0 V (± 10 digits)		.5400
0.3 V (± 3 digits)		.5333
0.1 V (± 10 digits)		.6400
30 mV (± 3 digits)		.6533
10 mV (± 1 digit)		.7800
3 mV (± 1 digit)		.8000
1 mV (± 1 digit)		1.0000

d. Wideband Output Flatness

- (1) Connect equipment as shown in figure 13. Press the **WBND** pushbutton on the ac measurement standard.

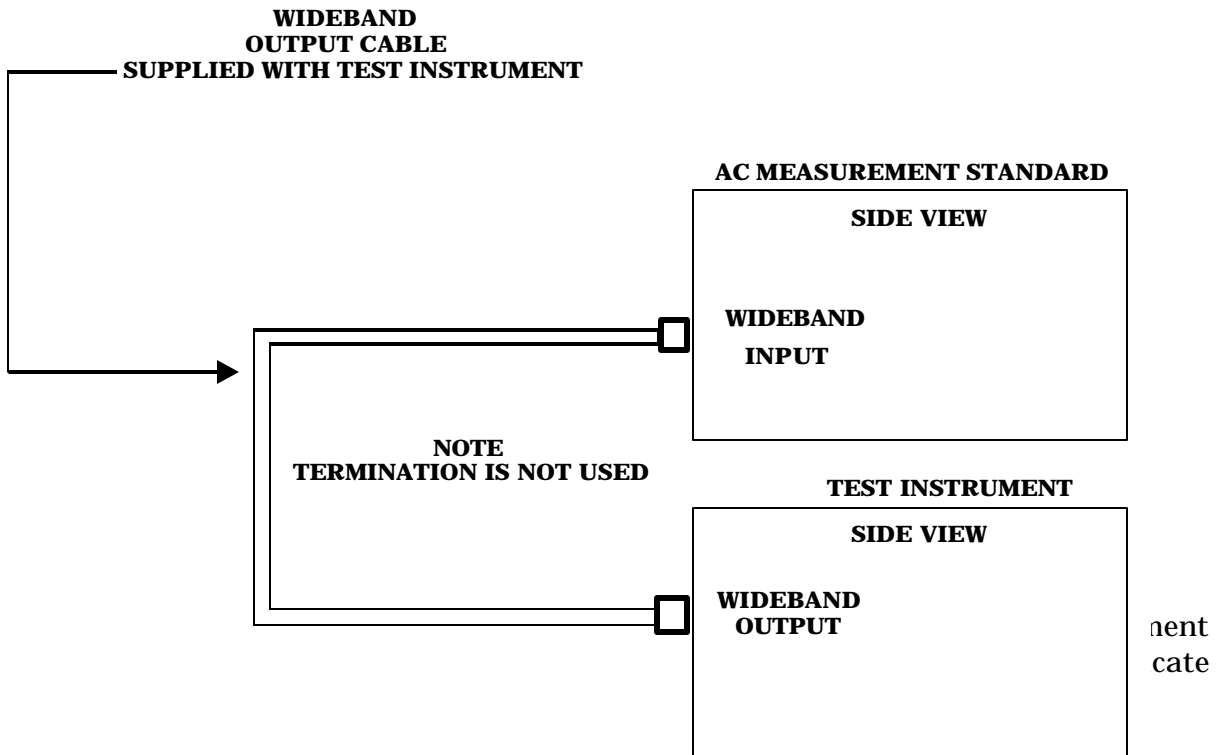

8
1

When **SET REF** is engaged the display shows the difference between an applied input and the stored reference, or average of references. The difference can be displayed in units of V (or mV), ppm, percent, or ratio. Once a reference has been established you can cycle through each choice by pressing any of the three softkeys below the display. The display will cycle through **PPM** (power on state), **PCT**, **VOLTS**, and **RATIO**, and displays the equation used in each case.

(3) Set TI to frequencies listed in table 11 for 3.0 V output level. At each frequency, record ac measurement standard error indication [(Vin - Ref)/Ref indication] in flatness error column of table 11 (include polarity). Flatness error will be within the limits specified; if not, perform e below.

- (4) Press **CLEAR REF WBND** soft key.
- (5) Repeat technique of (2) through (4) above for the remaining output levels listed in table 11.

Table 11. Wideband Output Flatness

Test instrument						
Output frequency	Output level 3.0 V		Output level 1.0 V		Output level 300 mV	
	Flatness error	Limits ± (%)	Flatness error	Limits ± (%)	Flatness error	Limits ± (%)
10 Hz		0.3000	---	---	---	---
30 Hz		0.1000	---	---	---	---
10 kHz		0.1000		0.1000		0.100
120 kHz		0.1000		0.1000		0.100
500 kHz		0.1001		0.1003		0.101
2 MHz		0.1001		0.1003		0.101
5 MHz		0.2001		0.2003		0.201
10 MHz		0.2001		0.2003		0.201
20 MHz		0.4001		0.4003		0.401
30 MHz		1.0001		1.0003		1.001

Test Instrument						
Output frequency	Output level 100 mV		Output level 30 mV		Output level 10 mV	
	Flatness error	Limits ± (%)	Flatness error	Limits ± (%)	Flatness error	Limits ± (%)
10 kHz		0.100		0.10		0.10
120 kHz		0.100		0.10		0.10
500 kHz		0.103		0.11		0.13
2 MHz		0.103		0.11		0.13
5 MHz		0.203		0.21		0.23
10 MHz		0.203		0.21		0.23
20 MHz		0.403		0.41		0.43
30 MHz		1.003		1.01		1.03

Test instrument				
Output frequency	Output level 3 mV		Output level 1 mV	
	Flatness error	Limits ± (%)	Flatness error	Limits ± (%)
10 Hz		0.10		0.10
120 kHz		0.10		0.10
500 kHz		0.20		0.50
2 MHz		0.20		0.50
5 MHz		0.40		0.70
10 MHz		0.40		0.70
20 MHz		0.60		0.90
30 MHz		1.60		3.00

e. Wideband Flatness Calibration

NOTE

Paragraphs **b** through **d** above comprise the verification test for the wideband option. Paragraph **e** below is the flatness calibration procedure. Performance of **e** below is only required if an out-of-tolerance condition exists in **b** and **d** above or upon initial calibration of wideband option. In both cases paragraphs **a** and **c** above must be completed prior to **e** below in order to establish, or characterize, voltage accuracies at 1 kHz (**c** above must be in tolerance prior to performing **e** below).

- (1) Connect equipment as shown in figure 13.
- (2) Set rear panel **CALIBRATION NORMAL/ENABLE** switch to **ENABLE**.
- (3) Press the **WBND** pushbutton on the ac measurement standard.
- (4) Call up the TI wideband flatness calibration routine by pressing the soft key sequence **SETUP MENUS, CAL, CAL** (again) and **WIDEBAND FLAT**.
- (5) Enter the present ambient air temperature as prompted and press **ENTER**; press **ENTER** again.
- (6) Press **OPERATE** pushbutton. Wideband flatness calibration starts with a nominal 3 V at 1 kHz output. If TI displayed value is not 3.00000 V, use output adjustment knob to enter this value. When this is completed, the **Error** indication should indicate 0.0 ppm.
- (7) When the ac measurement standard settles to a reading, press the **SET REF** soft key. (This is the 3 V reference value from which all 3 V frequencies will be compared.)
- (8) Press **ENTER** pushbutton; the frequency will advance to the next value.
- (9) Adjust the TI output adjustment knob to bring the ac measurement standard error display to indicate 0 PPM (± 30 PPM); then press **ENTER** pushbutton.
- (10) Repeat (9) above for each frequency displayed through 30 MHz.
- (11) Press the **CLEAR REF WBND** soft key on the ac measurement standard. The TI wideband output should nominally be 1 V, 1 kHz. If TI displayed value is not 1.00000 V, use output adjustment knob to enter this value. When this is completed, the **Error** indication should indicate 0.0 ppm.

(12) When the ac measurement standard settles to a reading, press the **SET REF** soft key. (This is the 1 V reference value from which all 1 V frequencies will be compared.)

(13) Press **ENTER** pushbutton; the frequency will advance to the next value.

(14) Adjust the TI output adjustment knob to bring the ac measurement standard error display to indicate 0 PPM (± 10 PPM); then press **ENTER** pushbutton.

(15) Repeat (14) above for each frequency displayed through 30 MHz.

(16) Press the **CLEAR REF WBND** soft key on the ac measurement standard. The TI wideband output should nominally be 300 mV, 1 kHz. If TI displayed value is not 300.000 mV, use output adjustment knob to enter this value. When this is completed, the **Error** indication should indicate 0.0 ppm.

(17) When the ac measurement standard settles to a reading, press the **SET REF** soft key. (This is the 300 mV reference value from which all 300 mV frequencies will be compared.)

(18) Press **ENTER** pushbutton, the frequency will advance to the next value.

(19) Adjust the TI output adjustment knob to bring the ac measurement standard **Error** display to indicate 0 PPM (± 30 PPM), then press **ENTER** pushbutton.

(20) Repeat (19) above for each frequency displayed through 30 MHz.

(21) Press the **CLEAR REF WBND** soft key on the ac measurement standard. The TI wideband output should nominally be 100 mV, 1 kHz. If TI displayed value is not 100.000 mV, use output adjustment knob to enter this value. When this is completed, the **Error** indication should indicate 0.0 ppm.

(22) When the ac measurement standard settles to a reading, press the **SET REF** soft key. (This is the 100 mV reference value from which all 100 mV frequencies will be compared.)

(23) Press **ENTER** pushbutton; the frequency will advance to the next value.

(24) Adjust the TI output adjustment knob to bring the ac measurement standard **Error** display to indicate 0 PPM (± 10 PPM), then press **ENTER** pushbutton.

(25) Repeat (24) above for each frequency displayed through 30 MHz. Only the 10 MHz, 20 MHz and 30 MHz points are adjusted.

(26) Press the **CLEAR REF WBND** soft key on the ac measurement standard. The TI wideband output should nominally be 30 mV, 1 kHz. If TI displayed value is not 30.0000 mV, use output adjustment knob to enter this value. When this is completed, the **Error** indication should indicate 0.0 ppm.

(27) When the ac measurement standard settles to a reading, press the **SET REF** soft key. (This is the 30 mV reference value from which all 30 mV frequencies will be compared.)

TB 9-6695-293-50

- (28) Press **ENTER** pushbutton; the frequency will advance to the next value.
- (29) Adjust the TI output adjustment knob to bring the ac measurement standard error display to indicate 0 PPM (± 30 PPM); then press **ENTER** pushbutton.
- (30) Repeat (29) above for each frequency displayed through 30 MHz.
- (31) Press the **CLEAR REF WBND** soft key on the ac measurement standard. The TI wideband output should nominally be 10 mV, 1 kHz. If TI displayed value is not 10.0000 mV, use output adjustment knob to enter this value. When this is completed, the **Error** indication should indicate 0.0 ppm.
- (32) When the ac measurement standard settles to a reading, press the **SET REF** soft key. (This is the 10 mV reference value from which all 10 mV frequencies will be compared.)
- (33) Press **ENTER** pushbutton, the frequency will advance to the next value.
- (34) Adjust the TI output adjustment knob to bring the ac measurement standard error display to indicate 0 PPM (± 10 PPM), then press **ENTER** pushbutton.
- (35) Repeat (34) above for each frequency displayed through 30 MHz. Only the 10 MHz, 20 MHz, and 30 MHz points are adjusted.
- (36) Ensure that rear panel **CALIBRATION NORMAL/ENABLE** switch is in the **ENABLE** position. Store the values by pressing the **STORE VALUES** soft key.
- (37) Press the **DONE WITH CAL** soft key.
- (38) When TI display returns to normal, set rear panel **CALIBRATION NORMAL/ ENABLE** switch to **NORMAL**.
- (39) Press **RESET** pushbutton.
- (40) Repeat (or perform initially) paragraphs **a** through **e** above.

15. Final Procedure

- a.** Deenergize and disconnect all equipment.
- b.** Annotate and affix DA label/form in accordance with TB 750-25.

**SECTION IV
CALIBRATION PROCESS FOR
AMPLIFIER, JOHN FLUKE, MODEL 5725A/()**

16. Preliminary Instructions

a. The instructions outlined in paragraphs **16** and **17** are preparatory to the calibration process. Personnel should become familiar with the entire bulletin before beginning the calibration.

b. Items of equipment used in this procedure are referenced within the text by common name as listed in table 2.

c. Unless otherwise specified, verify the results of each test and, whenever the test requirement is not met, take corrective action before continuing with the calibration. Additional maintenance information is contained in the manufacturer's manual for this TI.

d. Unless otherwise specified, all controls and control settings refer to the calibrator connected to the TI.

17. Equipment Setup

WARNING

HIGH VOLTAGE is used or exposed during the performance of this calibration. DEATH ON CONTACT may result if personnel fail to observe safety precautions. REDUCE OUTPUT(S) to a minimum after each step within the performance check where applicable.

a. Connect TI to calibrator, John Fluke, Model 5700A/(). The calibrator does not necessarily have to be the one normally used with the TI.

b. Connect TI and calibrator to a 115 V ac source.

c. Set TI and calibrator power switches to **ON** and allow 30 minutes warm-up.

18. Artifact Calibration - 5725A/()

a. If TI is being calibrated in conjunction with a 5700A/() calibrator, the artifact calibration should have already been performed; therefore, proceed to paragraph **19** below.

b. If TI is being calibrated separately, perform paragraph **8** above (Artifact Calibration) prior to proceeding to paragraph **19** below.

NOTE

In both cases, the TI will have to be connected to the 5700A and in the **ON** state.

19. High Ac Voltage

a. Connect equipment as shown in figure 14. Press **INPUT 2** pushbutton on ac measurement standard.

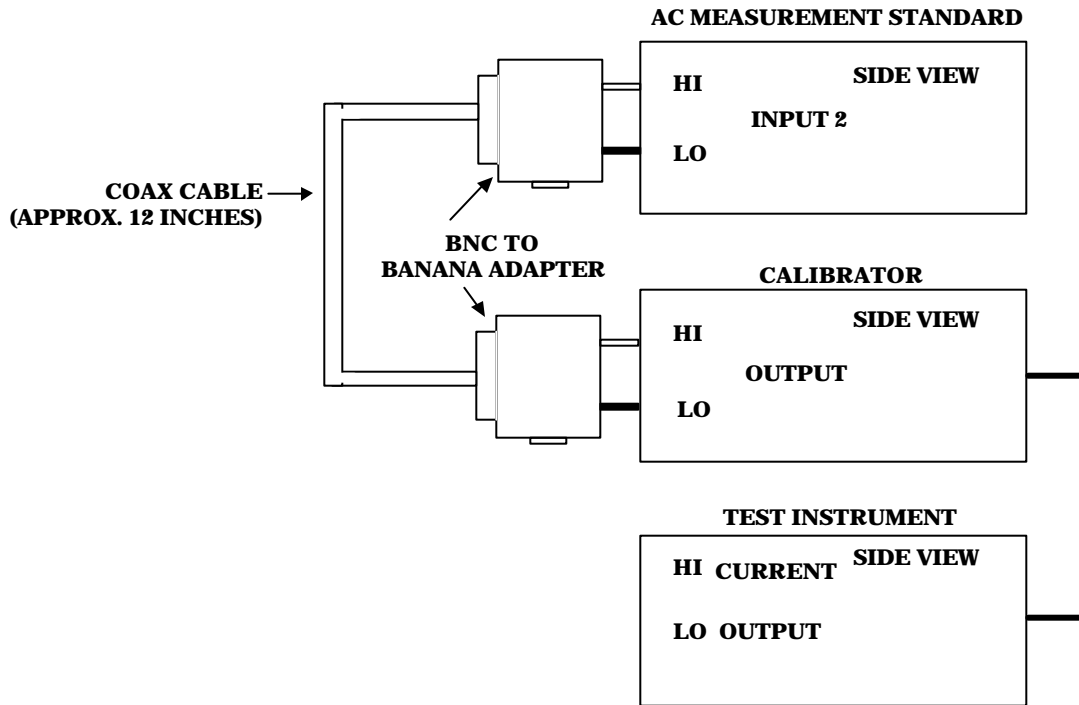

Figure 14. High ac voltage accuracy.

b. On the ac measurement standard, press the **UTIL MENUS** pushbutton and then the **MEAS CONTROL** soft key. Set **DIGITAL FILTER MODE** to **FAST** and **RESTART** to **MEDIUM**. Press the **DONE** soft key twice to return to the measurement display.

c. Set ac measurement standard to manual 700 V range.

d. Set the TI for a 300 V, 20 kHz output. Adjust TI output adjustment knob for an indication of 300.000 V (± 1 digit) on the ac measurement standard.

e. Record calibrator **Error** display indication in table 14 (page 39). Verify that the result is within the limits listed.

f. Repeat technique of **d** and **e** above for the remaining output levels and frequencies listed in table 12. In **d** above, ± 2 digits can be used for output levels of 600 and 1000 V.

Table 12. High Ac Voltage

Test instrument		Measured error (%)	Limits (0 \pm %)
Output level	Frequency		
300 V	20 kHz		0.0185
600 V	50 kHz		0.0618
600 V	100 kHz		0.2375
Set ac measurement standard to 1 kV range			
1000 V	20 kHz		0.0171
1000 V	30 kHz		0.0611
1000 V	40 Hz		0.0094

g. Set TI to **STANDBY**; then press **RESET**.

20. Dc Current Verification

a. Connect equipment as shown in figure 15.

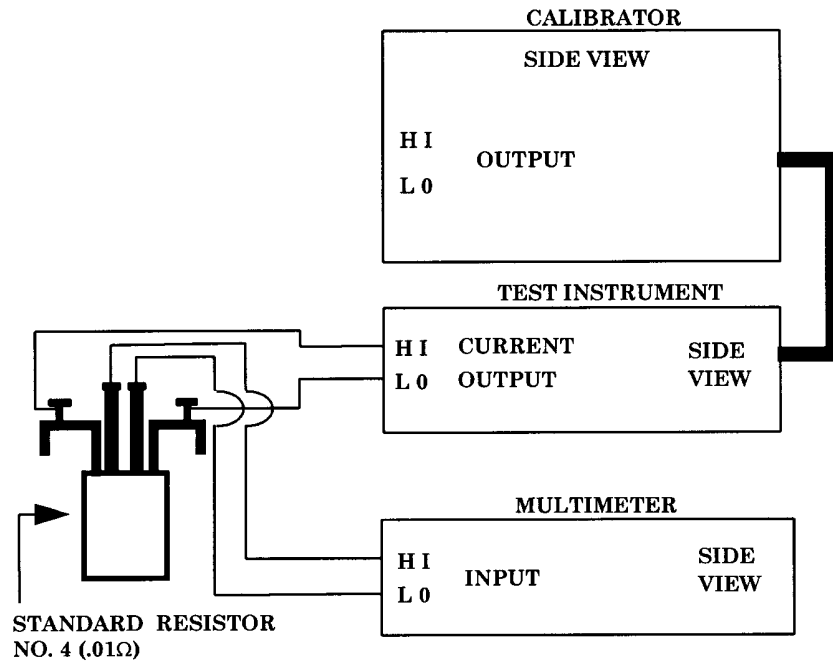

Figure 15. Dc current (5 and 10 A).

TB 9-6695-293-50

- b.** Configure multimeter for most accurate dc voltage measurements.
- c.** Set TI for a +10.0 A dc output.
- d.** Allow approximately 10 minutes for stabilization; then record multimeter indication.
- e.** Calculate measured value by dividing multimeter indication by test report value for standard resistor No. 4. Resulting value will be between 9.99592 and 10.00408 A (4.99772 and 5.00228); if not, perform **b** below.
- f.** Calculate percent of error for only +10 A dc and record for use in paragraph **21c** below.

NOTE

The following formula may be used to calculate percent of error:

$$\frac{\text{Measured Value} \times 100}{\text{Nominal Value}} - 100 = \text{Error (\%)}$$

- g.** Press +/- then **ENTER** pushbutton.
- h.** Repeat technique of **d** and **e** above with a -10.0 A dc output. Resulting value will be between -999592 and -10.00408 A (-4.99772 and -5.00228).
- i.** Repeat technique of **c** through **h** above for 5 A dc, using values in parenthesis.
- j.** Set to **STANDBY**; then press **RESET**.

21. Ac Current Verification

- a.** Connect equipment as shown in figure 16. Press **INPUT 1** pushbutton on ac measurement standard.

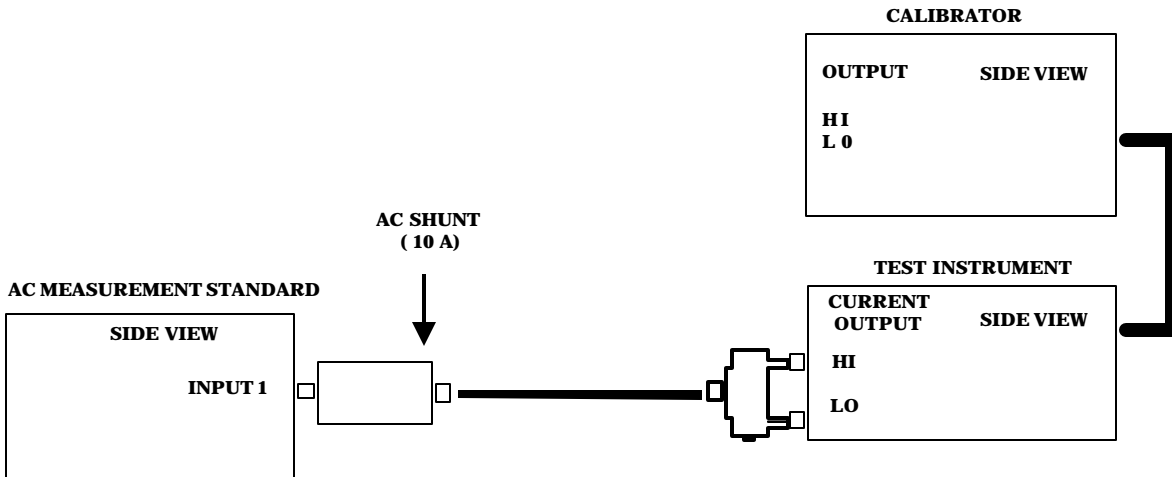

Figure 16. Ac current (10 A)

b. Enter the ac-to-dc difference corrections for ac shunt at each frequency in the appropriate column of table 13.

Table 13. Ac Current

Test instrument output		Ac measurement standard error display	Ac shunt ac-to dc difference	Calculated error (±%)	Error limits (±%)
Current	Frequency				
10.0 A	1.0 kHz				0.0477
10.0 A	40 Hz				0.0477
10.0 A	5 kHz				0.0988
10.0 A	10 kHz				0.3675

c. Set TI for a 10 A dc output. Adjust output adjustment control for an **Error** display equal to the previously recorded calculated error for + 10 A as recorded in paragraph 20f.

d. Press **NEW REF** pushbutton.

e. Allow at least 30 minutes for shunt stabilization. When the reading has settled, press **SET REF** soft key on ac measurement standard and set display to indicate PCT units.

TB 9-6695-293-50

NOTE

The 30 minute stabilization may only be required for the first measurement. Afterwards allow at least 2 to 5 minutes after each TI output frequency change before noting TI or ac measurement standard indication.

NOTE

When **SET REF** is engaged the display shows the difference between an applied input and the stored reference, or average of references. The difference can be displayed in units of V (or mV), ppm, percent, or ratio. Once a reference has been established you can cycle through each choice by pressing any of the three softkeys below the display. The display will cycle through **PPM** (power on state), **PCT**, **VOLTS**, and **RATIO**, and displays the equation used in each case.

f. Set TI for 10.0 A, 1.0 kHz ac output. Record ac measurement standard displayed error indication in appropriate column of table 13.

g. Return to error corrected +10.0 A dc output that was set in **c** above and verify that the ac measurement standard error display returns to a zero reading ± 0.010 PCT within 1 to 3 minutes; if not, set a new reference on ac measurement standard by pressing **CLEAR REF INPUT 1** soft key, then press **SET REF** softkey. Repeat **f** above.

h. Algebraically add the ac measurement standard error indication recorded in **f** above to the test reported ac-to-dc difference of the ac shunt. The result will be within the limits specified.

i. Repeat technique of **f** and **g** above for remaining frequencies listed in table 13. At each frequency, record the ac measurement standard error indication. Algebraically add the resulting error indication to the associated test reported ac-to-dc difference of the ac shunt. The result will be within the limits specified.

22. Final Procedure

a. Deenergize and disconnect all equipment.

b. Annotate and affix DA label/form in accordance with TB 750-25.

**SECTION V
CALIBRATION PROCESS FOR
POWER AMPLIFIER, JOHN FLUKE, MODEL 5215A/CT**

23. Preliminary Instructions

- a.** The instructions outlined in paragraphs **23** and **24** are preparatory to the calibration process. Personnel should become familiar with the entire bulletin before beginning the calibration.
- b.** Items of equipment used in this procedure are referenced within the text by common name as listed in table 2.
- c.** Unless otherwise specified, verify the results of each test and, whenever the test requirement is not met, take corrective action before continuing with the calibration. Adjustments required to calibrate the TI are included in this procedure. Additional maintenance information is contained in the manufacturer's manual for this TI.
- d.** Unless otherwise specified, all controls and control settings refer to the TI.

24. Equipment Setup

WARNING

HIGH VOLTAGE is used or exposed during the performance of this calibration. DEATH ON CONTACT may result if personnel fail to observe safety precautions. REDUCE OUTPUT(S) to minimum after each step within the performance check where applicable.

NOTE

When indications specified in paragraph **25** are not within tolerance, perform the power supply check in paragraph **26** prior to making adjustments. After adjustments are made, repeat paragraph **25**. Do not perform power supply check if all other parameters are within tolerance.

- a.** Remove protective cover on TI, as required, for making adjustments.
- b.** Connect TI to calibrator, John Fluke, Model 5700A/CT. The calibrator should be the one normally used with the TI and should have been recently calibrated.
- c.** Connect TI and calibrator to a 115 V ac source.

25. High Ac Voltage

a. Performance Check

(1) Connect equipment as shown in figure 17. Press **INPUT 2** pushbutton on ac measurement standard.

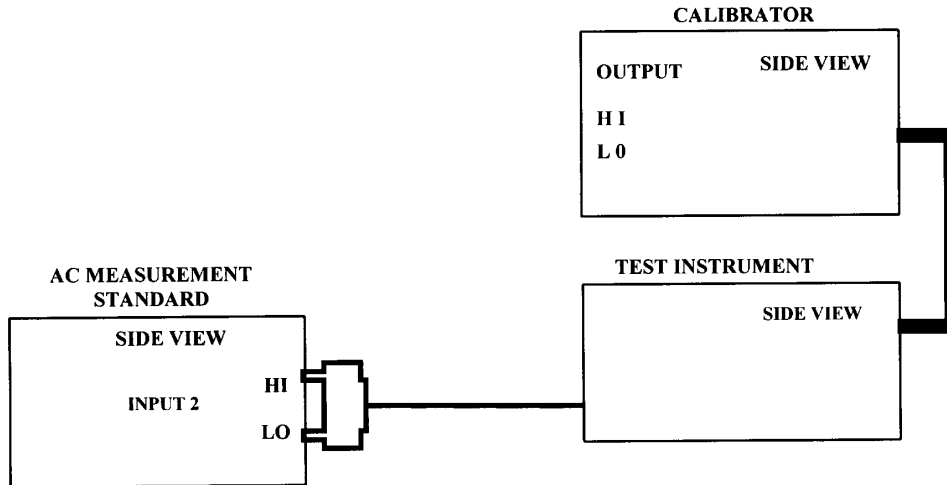

Figure 17. High voltage

NOTE

Ensure that **OUTPUT LOW** and (chassis ground) terminal connecting strap is securely in place on TI.

(2) Set both TI and calibrator **POWER** switches to **ON**. Allow at least 1 hour for equipment to warm up and stabilize.

NOTE

The operation of the TI is controlled by the calibrator. The TI controls referred to in the remainder of this check are located on the calibrator.

(3) On the ac measurement standard, press the **UTIL MENUS** pushbutton and then the **Meas Control** soft key. Set **DIGITAL FILTER MODE** to **FAST** and **RESTART** to **MEDIUM**. Press the **DONE** soft key twice to return to the measurement display.

(4) Set for a 1000 V, 1 kHz output and press **BOOST** to enable TI output. Adjust TI output adjustment knob for an indication of 1000.000 V (± 2 digits) on the ac measurement standard.

(5) Record calibrator **Error** display indication in table 14. Verify that the result is within the limits listed, if not perform **b(1)** below.

(6) Set for a 600 V, 100 kHz output. Adjust TI output adjustment knob for an indication of 600.000 V (± 2 digits) on the ac measurement standard.

(7) Record calibrator **Error** display indication in table 14. Verify that the result is within the limits listed, if not perform **b(2)** below.

(8) Repeat technique of (6) and (7) above for the remaining output levels and frequencies listed in table 14.

Table 14. High Ac Voltage

Test instrument		Measured error (%)	Limits (0 \pm %)
Output level	Frequency		
1000 V	1.0 kHz		0.0420
600 V	100 kHz		0.2000
600 V	50 kHz		0.0883
1000 V	20 kHz		0.0420
1000 V	40 Hz		0.0500
1000 V	20 Hz		0.1250

(9) Set to **STANDBY**; then press **RESET**.

b. Adjustments

(1) Adjust R9, LF GAIN (fig. 18) for TI measured output between 0.99990 and 1.00010 kV. (R)

(2) Adjust C14, HF GAIN (fig. 18) for TI measured output between 0.99990 and 1.00010 kV. (R)

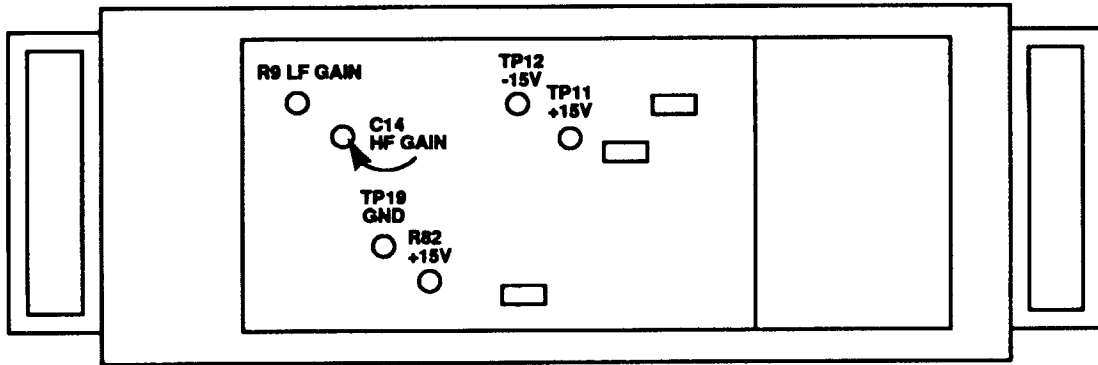

2

a. Performance Check

NOTE

Do not perform power supply check if other parameter is within tolerance.

(1) Connect digital multimeter between TP 11 +15V and TP 19 GND (fig. 18). If digital multimeter does not indicate between 14.95 and 15.05 V, perform **b** below.

(2) Connect digital multimeter between TP12 -15V and TP19 GND (fig. 18). Digital multimeter will indicate between -14.65 and -15.35 V.

b. Adjustments. Adjust R82 +15V (fig. 18) for a digital multimeter indication between +14.95 and 15.05 V dc. (R)

27. Final Procedure

- a. Deenergize and disconnect all equipment.
- b. Annotate and affix DA label/form in accordance with TB 750-25.

SECTION VI
CALIBRATION PROCESS FOR
TRANSCONDUCTANCE AMPLIFIER
JOHN FLUKE, MODEL 5220A/CT

28. Preliminary Instructions

a. The instructions outlined in paragraphs **28** and **29** are preparatory to the calibration process. Personnel should become familiar with the entire bulletin before beginning the calibration.

b. Items of equipment used in this procedure are referenced within the text by common name as listed in table 2.

c. Unless otherwise specified, verify the results of each test and, whenever the test requirement is not met, take corrective action before continuing with the calibration. Adjustments required to calibrate the TI are included in this procedure. Additional maintenance information is contained in the manufacturer's manual for this TI.

d. Unless otherwise specified, all controls and control settings refer to the TI.

29. Equipment Setup

WARNING

HIGH VOLTAGE is used or exposed during the performance of this calibration. DEATH ON CONTACT may result if personnel fail to observe safety precautions. REDUCE OUTPUT(s) to minimum after each step within the performance check where applicable.

a. Remove TI protective covers, as required, for adjustments.

b. Connect TI to a 115 V ac source.

c. Connect equipment as shown in figure 19, except do not connect calibrator to TI at this point.

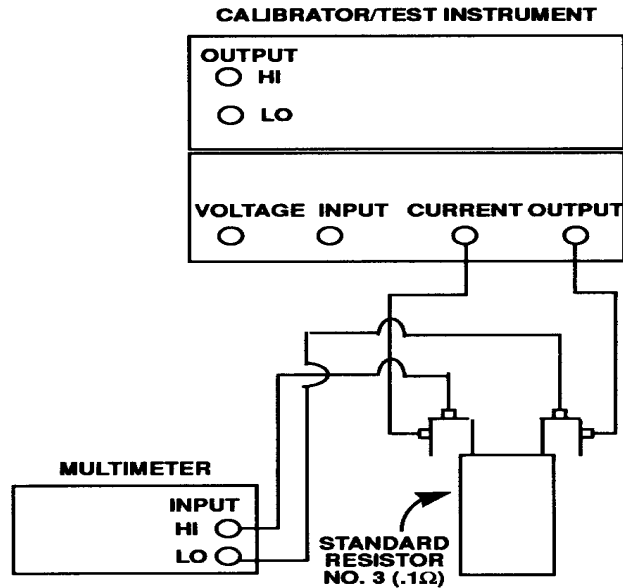

Figure 19. Dc current.

- d. Set TI and calibrator **POWER** switches to **ON** and allow at least 30 minutes before proceeding.
- e. Configure multimeter for most accurate dc voltage measurements.
- f. Ensure TI is in **STBY** mode; multimeter will indicate $0 \pm 1 \mu\text{V}$.
- g. Connect a short jumper wire between the front **VOLTAGE INPUT HI** and **LO** terminals.
- h. Set to **OPR** mode. Multimeter will indicate $0 \pm 100 \mu\text{V}$ dc; if not, adjust R6 on the A5 preamplifier PCB assembly (fig. 20).
- i. Set to **STBY** mode and remove jumper **VOLTAGE INPUT** terminals.
- j. Set TI and calibrator **POWER** switches to **OFF**.
- k. Connect TI to calibrator, John Fluke, Model 5700A/CT. The calibrator should be the one normally used with the TI and should have been recently calibrated.
- l. Set TI and calibrator **POWER** switches to **ON** and allow sufficient time to restabilize.

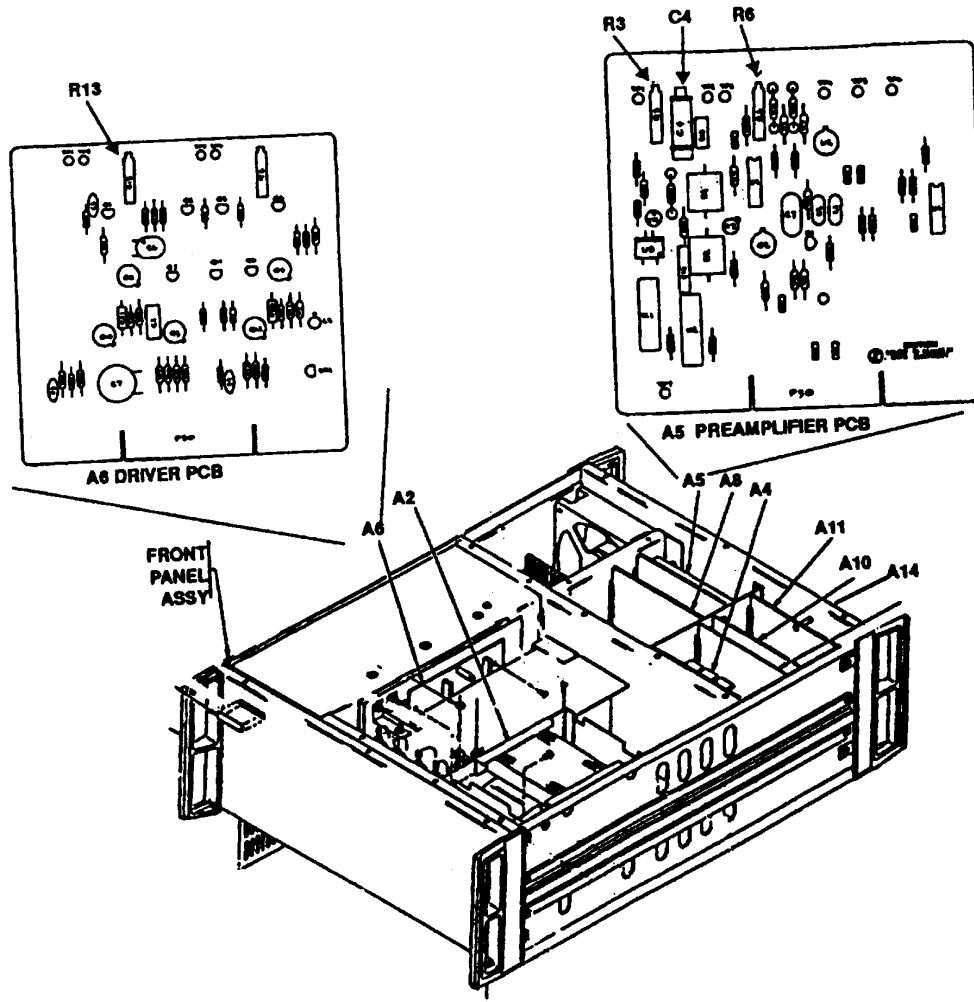

Figure 20. John Fluke, Model 5220A/CT - board location.

NOTE

The operation of the TI is controlled by the calibrator. The TI controls referred to in the remainder of this check are located on the calibrator.

30. Dc Accuracy and Line Regulation

a. Performance Check

- (1) Replace standard resistor No. 3 (.1Ω) with standard resistor No. 4 (.01Ω).
- (2) Set TI for a +10.0 A dc output.

TB 9-6695-293-50

(3) Allow approximately 10 minutes for stabilization; then record multimeter indication.

(4) Calculate output current by dividing multimeter indication by test report value for standard resistor No. 4. Resulting value will be between 9.996 and 10.004 A (4.9975 and 5.0025); if not, perform **b** below.

(5) Press +/- then **ENTER** pushbuttons.

(6) Repeat technique of (3) and (4) above with a -10.0 A dc output. Resulting value will be between -9.996 and -10.004 A (-4.9975 and -5.0025).

(7) Repeat technique of (2) through (6) above for 5 A dc, using values in parenthesis.

(8) Replace standard resistor No. 4 (.01 Ω) with standard resistor No. 5 (.001 Ω).

(9) Set TI for a +20.0 A dc output.

(10) Repeat technique of (3) and (4) above for 20 A. Calculated value will be between 19.987 and 20.013 A.

(11) Set to **STANDBY**.

b. Adjustments. Adjust R3 on the A5 preamplifier assembly (fig. 19) for an indication on the multimeter that is 10 times the test report value of standard resistor No. 4 ± 0.002 mV (multimeter indication). For example, if the test report value is 0.0100253 Ω , adjust R3 for a multimeter indication of 0.100253 V dc ± 0.002 mV dc. (R)

31. Frequency Response

a. Performance Check

(1) Connect equipment as shown in figure 21. Press **INPUT 1** pushbutton on ac measurement standard.

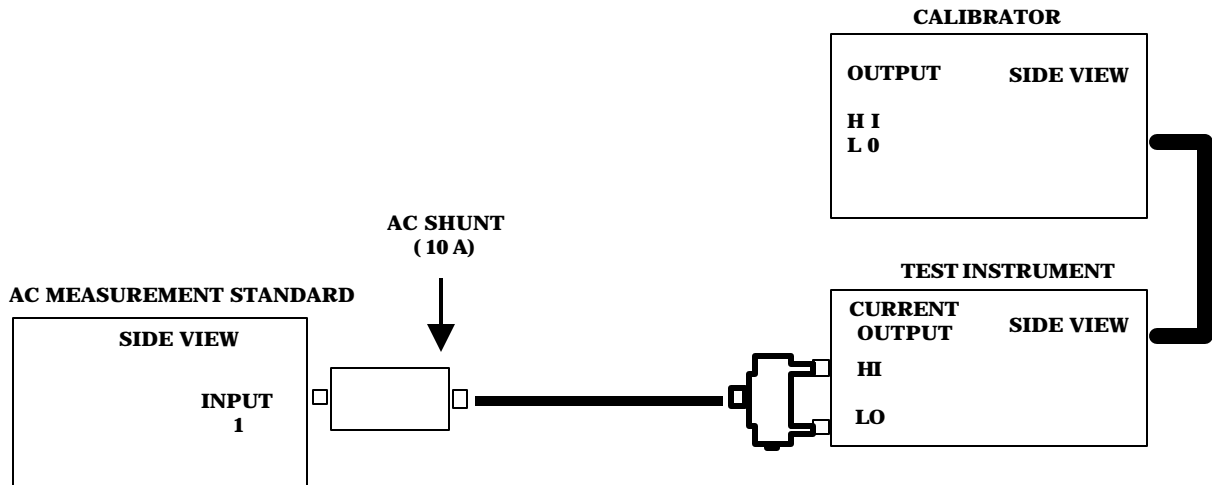

Figure 21. Frequency response.

- (2) Enter the ac-to-dc difference corrections for ac shunt at each frequency in the appropriate column of table 15.
- (3) Set TI for a 10 A dc output.
- (4) Allow 30 minutes for ac shunt to stabilize.

NOTE

The 30 minute stabilization may only be required for the first measurement. Afterwards allow at least 2 to 5 minutes after each TI output frequency change before noting TI or ac measurement standard indication.

NOTE

When **SET REF** is engaged the display shows the difference between an applied input and the stored reference, or average of references. The difference can be displayed in units of V (or mV), ppm, percent, or ratio. Once a reference has been established you can cycle through each choice by pressing any of the three softkeys below the display. The display will cycle through **PPM** (power on state), **PCT**, **VOLTS**, and **RATIO**, and displays the equation used in each case.

- (5) Set TI for 10.0 A, 1.0 kHz ac output. Record ac measurement standard displayed **Error** indication in appropriate column of table 15.

TB 9-6695-293-50

(6) Return to +10.0 A dc output. Verify that the ac measurement standard **Error** display returns to a zero reading ± 0.0010 PCT within 1 to 3 minutes; if not, set a new reference on ac measurement standard by pressing **CLEAR REF. INPUT 1** soft key, then press **SET REF** soft key. Repeat (5) above.

(7) Algebraically add the ac measurement standard **Error** indication recorded in 5 above to the test reported ac-to-dc difference of the ac shunt. The result will be within the limits specified; if not, perform **b.** below.

(8) Repeat technique of (5) and (6) above for remaining frequencies listed in table 15. At each frequency record the ac measurement standard **Error** indication. Algebraically add the resulting error indication to the associated test reported ac-to-dc difference of the ac shunt. The result will be within the limits specified; if not, perform **b** below.

Table 15. Ac Current

Test instrument output		Ac measurement standard Error display	Ac shunt ac-dc difference	Calculated error (\pm %)	Error limits (\pm %)
Current	Frequency				
10.0 A	1.0 kHz				0.16
10.0 A	20 Hz				0.16
10.0 A	5 kHz				0.17

b. Adjustments

(1) Set TI to **STANDBY**; then set TI for a 10 A, 1 kHz output.

(2) Allow 3 minutes for stabilization; set a new reference on ac measurement standard by pressing **CLEAR REF. INPUT 1** soft key, then press **SET REF** soft key.

(3) Change TI output frequency to 5 kHz; wait 1 minute, then adjust C4 on A5 PREAMPLIFIER PCB (fig.20) for a zero (± 0.010 PCT) **Error** indication on ac measurement standard. (R)

32. Final Procedure

a. Deenergize and disconnect all equipment.

b. Annotate and affix DA label/form in accordance with TB 750-25.

TB 9-6695-293-50

By Order of the Secretary of the Army:

Official:

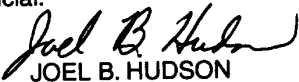
JOEL B. HUDSON
*Administrative Assistant to the
Secretary of the Army*
05268

DENNIS J. REIMER
*General, United States Army
Chief of Staff*

Distribution:

To be distributed in accordance with STD IDS No. RLC-1500, 6 March 1991,
requirements for calibration procedure TB 9-6695-293-50.

PIN NO: 052435-001